

MODELS | SJ 6826RT SJ 6832RT



# Operating Manual

Rough Terrain Compact Series (ANSI/CSA)

129951AF-A September 2010



**Skyjack Service Center** 3451 Swenson Ave. St. Charles, Illinois, 60174 USA

Phone: 630-262-0005

Toll Free: 1-800-275-9522

Fax: 630-262-0006

Email: [service@skyjack.com](mailto:service@skyjack.com)

**Parts (North America)**

Toll Free: 1-800-965-4626

Toll Free Fax: 1-888-782-4825

Email: [parts@skyjack.com](mailto:parts@skyjack.com)

**Parts & Service (Europe)** Unit 1 Maes Y Clawdd, Maesbury Road Industrial Estate

Oswestry, Shropshire SY10 8NN UK

Phone: +44-1691-676-235

Fax: +44-1691-676-238

Email: [info@skyjackeurope.co.uk](mailto:info@skyjackeurope.co.uk)

**Skyjack Asia Pacific**

Singapore

Phone: +65-6449-3710

Fax: +65-6449-7690

Email: [skyjack@singnet.com.sg](mailto:skyjack@singnet.com.sg)

---

The Safety Alert Symbol identifies important safety messages on aerial platform, safety signs in manuals or elsewhere. When you see this symbol, be alert to the possibility of personal injury or death. Follow the instructions in the safety message.



**This Safety Alert Symbol means attention!**

**Become alert! Your safety is involved.**



**DANGER**

**DANGER indicates an imminently hazardous situation which, if not avoided, will result in death or serious injury.**



**WARNING**

**WARNING indicates a potentially hazardous situation which, if not avoided, could result in death or serious injury.**



**CAUTION**

**CAUTION indicates a potentially hazardous situation which, if not avoided, may result in minor or moderate injury. It may also be used to alert against unsafe practices.**

**IMPORTANT**

**IMPORTANT indicates a procedure essential for safe operation and which, if not followed, may result in a malfunction or damage to the aerial platform.**

---

# Table of Contents

## Section 1 - About Your Aerial Platform

### Read and Heed

Aerial Platform Definition.....	7
Purpose of Equipment.....	7
Use of Equipment.....	7
Manual.....	7
Operator.....	7
Service Policy and Warranty.....	7
Optional Accessories.....	7
Scope of this Manual.....	7

### Safety Rules

Operator Safety Reminders.....	8
Electrocution Hazard.....	9
Safety Precautions.....	10

## Section 2 - Operation

2.1	General.....	13
2.1-1	Operator Qualifications.....	13
2.1-2	Operator's Responsibility for Maintenance.....	13
2.1-3	Maintenance and Inspection Schedule.....	13
2.1-4	Owner's Inspections.....	13
2.2	Major Components.....	14
2.3	Major Assemblies.....	15
2.3-1	Base.....	15
2.3-2	Lifting Mechanism.....	15
2.3-3	Platform.....	15
2.4	Serial Number Nameplate.....	15
2.5	Component Identification.....	16
2.5-1	Main Power Disconnect Switch.....	16
2.5-2	Motion Alarm.....	16
2.5-3	Tilt Alarm.....	16
2.5-4	Brake System.....	16
2.5-5	Emergency Lowering System.....	17
2.5-6	Free-wheeling Valve.....	17
2.5-7	Propane Cylinder.....	17
2.5-8	Base Control Console.....	18
2.5-9	Maintenance Support.....	19
2.5-10	Manual Storage Box.....	19
2.5-11	Platform Control Console.....	20
2.5-12	Folding Guardrail System.....	21
2.5-13	Safety Belt/Harness Attachment Bar.....	21
2.6	Component Identification (Special Options).....	22
2.6-1	Outrigger/Generator Control Console (If Equipped).....	22
2.6-2	800W AC Inverter (If Equipped).....	22
2.6-3	Tire Sealant (If Equipped).....	23
2.7	Operator's Responsibility.....	24
2.8	Visual and Daily Maintenance Inspections.....	25
2.9	Function Tests.....	34

---

## Table of Contents

### Section 2 - Operation (Continued)

2.10	Start Operation .....	41
2.10-1	To Activate Base Control Console .....	42
2.10-2	To Raise or Lower Platform Using Base Control Console .....	42
2.10-3	To Activate Platform Control Console .....	43
2.10-4	To Raise or Lower Platform Using Platform Control Console .....	43
2.10-5	To Drive Forward or Backward .....	44
2.10-6	To Steer .....	44
2.10-7	To Select Drive Torque .....	45
2.10-8	To Extend or Retract Manual Extension Platform .....	45
2.10-9	Hydraulic Outriggers (If Equipped) .....	46
2.10-10	Generator (If Equipped) .....	47
2.10-11	Electrical Inverter (If Equipped) .....	47
2.10-12	Shutdown Procedure .....	47
2.11	Refueling Procedure .....	48
2.11-1	Regular Fuel .....	48
2.11-2	Propane .....	49
2.12	Loading/Unloading .....	50
2.12-1	Lifting .....	50
2.12-2	Driving .....	51
2.13	Guardrail Folding Procedure .....	52
2.14	Moving the Aerial Platform Through a Doorway .....	54
2.15	Winching and Towing Procedure .....	56
2.15-1	To Release Free-wheeling Valve .....	56
2.15-2	To Release Brakes Manually .....	57
2.16	Emergency Lowering Procedure .....	58
2.17	Maintenance Support Procedure .....	59
2.18	Tables .....	60
2.19	Labels .....	68

### List of Tables

Table 2.1	Standard and Optional Features .....	60
Table 2.2	Specifications and Features .....	61
Table 2.3	Owner's Annual Inspection Record .....	62
Table 2.4	Maximum Platform Capacities (Evenly Distributed) .....	63
Table 2.5	Floor Loading Pressure .....	64
Table 2.6	Maintenance and Inspection Schedule .....	66
Table 2.7	Operator's Checklist .....	67

**SKYJACK** is continuously improving and expanding product features on its equipment, therefore, specifications and dimensions are subject to change without notice.

### **Aerial Platform Definition**

A mobile device that has an adjustable position platform supported from ground level by a structure.

### **Purpose of Equipment**

The SKYJACK Rough Terrain Compact Series aerial platform is designed to transport and raise personnel, tools and materials to overhead work areas.

### **Use of Equipment**

The aerial platform is a highly maneuverable, mobile work station. Lifting and driving must be on a flat, level, compacted surface. It can be driven over uneven terrain only when the platform is fully lowered.

### **Manual**

The operating manual is considered a fundamental part of the aerial platform. It is a very important way to communicate necessary safety information to users and operators. A complete and legible copy of this manual must be kept in the provided weather-resistant storage compartment on the aerial platform at all times.

### **Operator**

The operator must read and completely understand both this operating manual and the safety panel label located on the platform and all other warnings in this manual and on the aerial platform. Compare the labels on the aerial platform with the labels found within this manual. If any labels are damaged or missing, replace them immediately.

### **Service Policy and Warranty**

SKYJACK warrants each new SJRT Compact Series work platform to be free of defective parts and workmanship for the first 24 months. Any defective part will be replaced or repaired by your local SKYJACK dealer at no charge for parts or labor. Contact the SKYJACK Service Department for warranty statement extensions or exclusions.

### **Optional Accessories**

The SKYJACK aerial platform is designed to accept a variety of optional accessories. These are listed under “Standard and Optional Features” in [Table 2.1](#). Operating instructions for these options (if equipped) are located in [Section 2](#) of this manual.

For non-standard components or systems, contact the SKYJACK Service Department at

☎ : 800 275-9522

☎ : 630 262-0006

Include the model and serial number for each applicable aerial platform.

### **Scope of this Manual**

- a. This manual applies to the ANSI/SIA, CSA version of the SJRT Compact Series aerial platform models listed on [Table 2.1](#).
  - **Equipment identified** with “ANSI” meets the ANSI SIA-A92.6-2006 standard.
  - **Equipment identified** with “CSA” meets the CSA B354.2-01 standard.
- b. **CSA (Canada)**

Operators are required to conform to national, territorial/provincial and local health and safety regulations applicable to the operation of this aerial platform.
- c. **ANSI/SIA (United States)**

Operators are required by the current ANSI/SIA A92.6 standards to read and understand their responsibilities in the manual of responsibilities before they use or operate this aerial platform.

**WARNING**

**Failure to comply with your required responsibilities in the use and operation of the aerial platform could result in death or serious injury!**

**Operator Safety Reminders**

A study conducted by St. Paul Travelers showed that most accidents are caused by the failure of the operator to follow simple and fundamental safety rules and precautions.

You, as a careful operator, are the best insurance against an accident. Therefore, proper usage of this aerial platform is mandatory. The following pages of this manual should be read and understood completely before operating the aerial platform.

Common sense dictates the use of protective clothing when working on or near machinery. Use appropriate safety devices to protect your eyes, ears, hands, feet and body.

Any modifications from the original design are strictly forbidden without written permission from SKYJACK.

**Electrocution Hazard**

This aerial platform is not electrically insulated. Maintain a Minimum Safe Approach Distance (MSAD) from energized power lines and parts as listed below. The operator must allow for the platform to sway, rock or sag. This aerial platform does not provide protection from contact with or proximity to an electrically charged conductor.

Per ANSI A92.6-2006 8.10(7)

“The operator shall perform only that work for which he or she is qualified, in compliance with all applicable safety related work practices intended to prevent electric shock covered by the Code of Federal Regulations (CFR) 1910.333. The operator’s level of competence shall be established only by persons qualified to do so. Operators shall maintain the appropriate minimum approach distance (MAD) from energized power lines and parts covered by CFR 1910.333 (c).”

Unqualified persons must maintain a minimum approach distance of 10 feet from any energized power line up to 50 kV. Energized power lines over 50 kV require a greater minimum approach distance to be maintained. Refer to CFR 1910.333.

As per CSA B354.2-01

“The operator shall maintain the minimum safe approach distance (MSAD) from energized conductors at all times in accordance with the authority having jurisdiction.”

As per AS 2550.1-2002

Elevating Work Platforms must remain 6.4 m from electrical distribution lines up to 133 kV and 8 m from transmission lines greater than 133 kV. State regulations may take precedence over these approach distances.

**DO NOT USE THE AERIAL PLATFORM AS A GROUND FOR WELDING.  
DO NOT OPERATE THE AERIAL PLATFORM DURING LIGHTNING OR STORMS.**

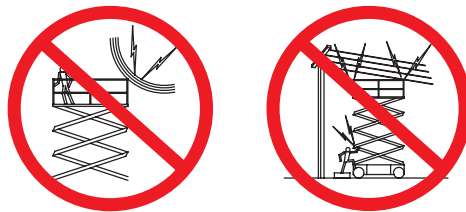

 <b>DANGER</b> Avoid Power Lines	
<b>Minimum Safe Approach Distance</b>	
<b>ANSI/SIA A92.6-2006 &amp; CSA B354.2-01 Requirements</b>	
Voltage Range (Phase to Phase)	Minimum Safe Approach Distance (Feet)
0 to 300V	Avoid Contact
Over 300V to 50KV	10
Over 50KV to 200KV	15
Over 200KV to 350KV	20
Over 350KV to 500KV	25
Over 500KV to 750KV	35
Over 750KV to 1000KV	45
<b>FAILURE TO AVOID THIS HAZARD WILL RESULT IN DEATH OR SERIOUS INJURY!</b>	

60023AD-ANSI



**Safety Precautions**

Know and understand the safety precautions before going on to next section.



**WARNING**

**Failure to heed the following safety precautions could result in tip over, falling, crushing, or other hazards leading to death or serious injury.**

- **KNOW** all national, state/provincial and local rules which apply to your aerial platform and jobsite.
- **TURN** emergency main power disconnect switch “O” off when leaving the aerial platform unattended. Remove the key to prevent unauthorized use of the aerial platform.
- **WEAR** all the protective clothing and personal safety devices issued to you or called for by job conditions.

- **DO NOT** wear loose clothing, dangling neckties, scarves, rings, wristwatches or other jewelry while operating this aerial platform.

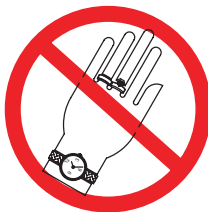

- **AVOID** entanglement with ropes, cords or hoses.



- **AVOID** falling. Stay within the boundaries of the guardrails.



- **DO NOT** raise the aerial platform in windy or gusty conditions.



- **DO NOT** increase the lateral surface area of the platform. Increasing the area exposed to the wind will decrease aerial platform stability.



- **DO NOT** drive or elevate the aerial platform if it is not on a firm level surface. Do not drive elevated near depressions or holes of any type, loading docks, debris, drop-offs and surfaces that may affect the stability of the aerial platform.



- **If operation in areas with holes or drop-offs is absolutely necessary**, elevated driving shall not be allowed. Position the aerial platform horizontally only with the platform fully lowered. After ensuring that all 4 wheels or outriggers (if equipped) have contact with level firm surface, the aerial platform can be elevated. After elevation, the drive function must not be activated.

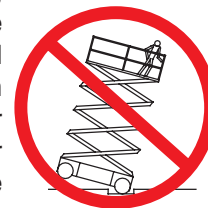

- **Elevated driving** must only be done on a firm level surface.

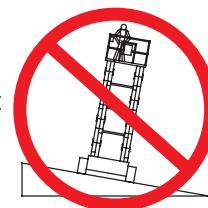

- **DO NOT** ascend or descend a grade when elevated. When fully lowered, ascending or descending, only grades up to rated maximum listed in [Table 2-2](#) are permissible.



### Safety Precautions (Continued)

Know and understand the safety precautions before going on to next section.

- **DO NOT** operate on surfaces not capable of holding the weight of the aerial platform including the rated load, e.g. covers, drains, and trenches.

- **DO NOT** operate an aerial platform that has ladders, scaffolding or other devices mounted on it to increase its size or work height. It is prohibited.



- **DO NOT** exert side forces on aerial platform while elevated.



- **DO NOT** use the aerial platform as a crane. It is prohibited.



- **DO NOT** sit, stand or climb on the guardrails. It is prohibited.



- **DO NOT** climb on scissor arm assembly. It is prohibited.



- **BE AWARE** of overhead obstructions or other possible hazards around the aerial platform when driving or lifting.

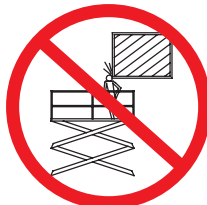

- **DO NOT** raise the aerial platform while the aerial platform is on a truck, fork lift or other device or vehicle.



- **BE AWARE** of crushing hazards. Keep all body parts inside platform guardrail.



- **DO NOT** lower the platform unless the area below is clear of personnel and obstructions.



- **ENSURE** that there are no personnel or obstructions in the path of travel, including blind spots.

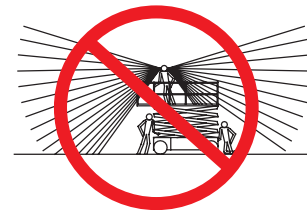

- **BE AWARE** of blind spots when operating the aerial platform.
- **STUNT** driving and horseplay are prohibited.
- **ENSURE ALL** tires are in good condition and lug nuts are properly tightened.
- **DO NOT** alter or disable limit switches or other safety devices.
- **DO NOT** use the aerial platform without guardrails, locking pins and the entry gate/chain/bar in place.

### Safety Precautions (Continued)

Know and understand the safety precautions before going on to next section.

- **DO NOT** exceed the rated capacity of the aerial platform. Do make sure the load is evenly distributed on the platform.
- **DO NOT** attempt to free a snagged platform with lower controls until personnel are removed from the platform.
- **DO NOT** position the aerial platform against another object to steady the platform.
- **DO NOT** place materials on the guardrails or materials that exceed the confines of the guardrails unless approved by Skyjack.

### Fall Protection

As per the ANSI A92.6-2006 standard, “The guardrail system of the aerial platform provides fall protection. If occupant(s) of the platform are required to wear personal fall protection equipment (PFPE), occupants shall comply with instructions provided by the aerial platform manufacturer (remanufacturer) regarding anchorage(s).”

If additional fall protection is required, by an employer or the authority having jurisdiction, Skyjack recommends the use of a fall restraint system to keep an occupant within the confines of the platform, and thus not expose the occupant to any fall hazard requiring a fall arrest.

All personal fall protection equipment must comply with applicable governmental regulations and must be inspected and used in accordance with the manufacturer’s recommendations.

All personal fall protection equipment must be attached only to approved anchorage points within the platform of the aerial platform.



### WARNING

**Entering and exiting the aerial platform should only be done using the three points of contact.**

- Use only equipped access openings.
- Enter and exit only when the aerial platform is in the fully retracted position.
- Do use three points of contact to enter and exit the platform. Enter and exit the platform from the ground only. Face the aerial platform when entering or exiting the platform.
- Three points of contact means that two hands and one foot or one hand and two feet are in contact with the aerial platform or the ground at all times during entering and exiting.



### WARNING

**An operator should not use any aerial platform that:**

- does not appear to be working properly.
- has been damaged or appears to have worn or missing parts.
- has alterations or modifications not approved by the manufacturer.
- has safety devices which have been altered or disabled.
- has been tagged or blocked out for non-use or repair.

**Failure to avoid these hazards could result in death or serious injury.**

### Jobsite Inspection

- Do not use in hazardous locations.
- Perform a thorough jobsite inspection prior to operating the aerial platform, to identify potential hazards in your work area.
- Be aware of moving equipment in the area. Take appropriate actions to avoid collision.

### 2.0 Operation

This section provides the necessary information needed to operate the aerial platform. It is important that the user reads and understands this section before operating the aerial platform.

#### 2.1 General

In order for this aerial platform to be in good working condition, it is important that the operator meets the necessary qualifications and follow the maintenance and inspection schedule referred to in this section.

##### 2.1-1 Operator Qualifications

- Only trained and authorized personnel shall be permitted to operate an aerial platform.
- Safe use of this aerial platform requires the operator to understand the limitations and warnings, operating procedures and operator's responsibility for maintenance. Accordingly, the operator must understand and be familiar with this operating manual, its warnings and instructions, and all warnings and instructions on the aerial platform.
- The operator must be familiar with employer's work rules and related government regulations and be able to demonstrate the ability to understand and operate this make and model of aerial platform in the presence of a qualified person.

##### 2.1-2 Operator's Responsibility for Maintenance



#### **WARNING**

**Maintenance must be performed by trained and competent personnel who are familiar with mechanical procedures.**

**Death or serious injury could result from the use of an aerial platform that is not properly maintained or kept in good working condition.**

- The operator must be sure that the aerial platform has been properly maintained and inspected before using it.
- The operator must perform all the daily inspections and function tests found in [Table 2.6](#), even if the operator is not directly responsible for the maintenance of this aerial platform.

##### 2.1-3 Maintenance and Inspection Schedule

- The inspection points covered in [Table 2.6](#) indicate the areas of the aerial platform to be maintained or inspected and at what intervals the maintenance and inspections are to be performed.
- The actual operating environment of the aerial platform may affect the maintenance schedule.



#### **WARNING**

**Use original or manufacturer-approved parts and components for the aerial platform.**

##### 2.1-4 Owner's Inspections

It is the responsibility of the owner to arrange daily, quarterly (or 150 hours) and annual inspections of the aerial platform. Refer to [Table 2.6](#) for recommended maintenance and inspection areas and intervals. A record of annual inspection is kept on a label located on the scissor assembly. Refer to [Table 2.3](#) in this manual.

2.2 Major Components

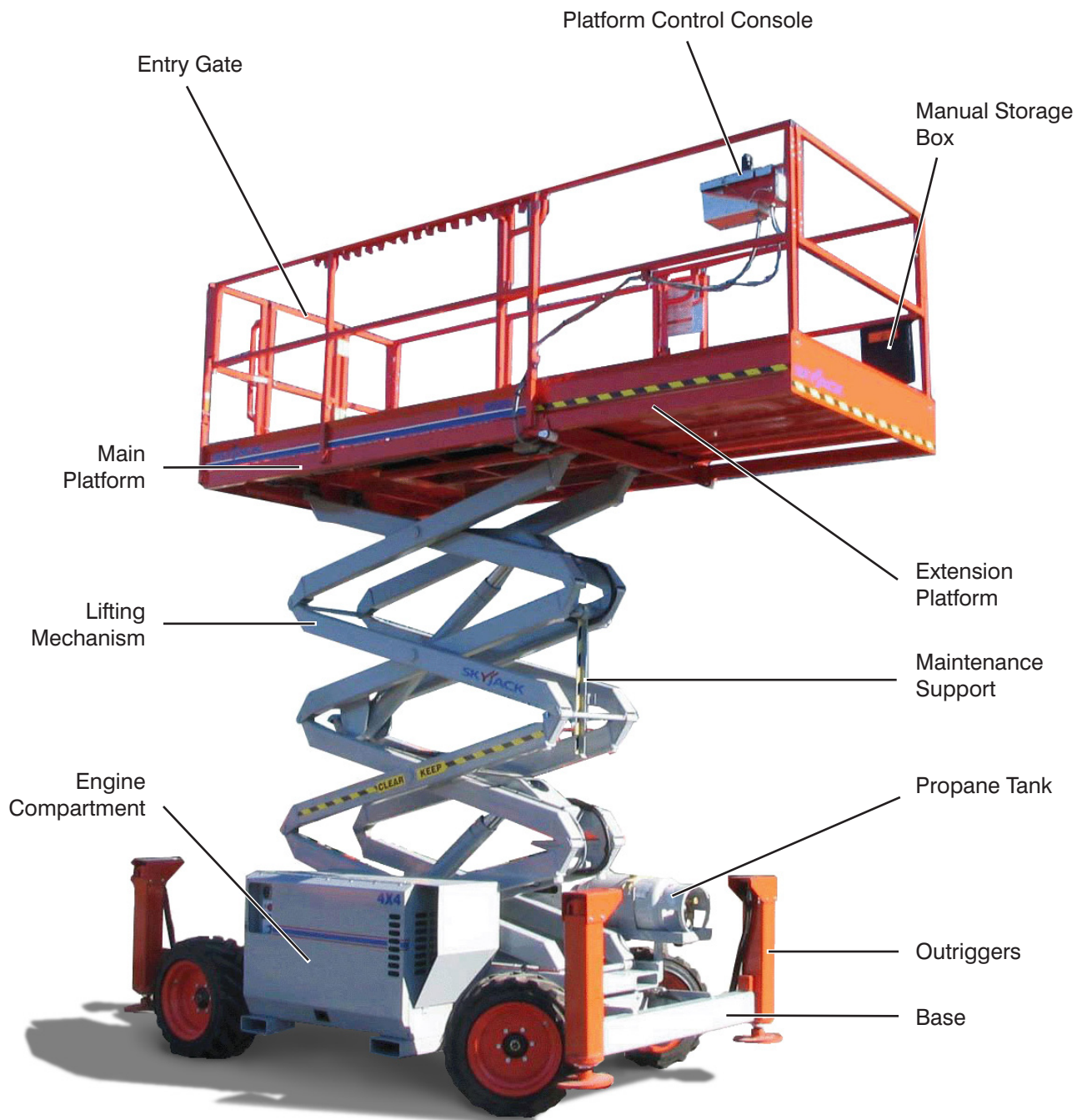

*SKYJACK Model SJ 6826RT Aerial Platform*

### 2.3 Major Assemblies

The aerial platform consists of three major assemblies: base, lifting mechanism and platform.

#### 2.3-1 Base

The base is a rigid, one-piece weldment which supports two side compartments.

- One compartment contains the engine, 12V battery, base control console and electrical components. The other compartment contains the emergency lowering system, brake release and hydraulic components as well as fuel and hydraulic tanks.
- The propane cylinders (if equipped) are located on both sides of the hydraulic/fuel compartment.
- The four wheels are hydraulically-motor driven with two front wheels steerable by a hydraulic cylinder.
- The rear wheel motors have spring-applied hydraulically released disc brakes.

#### 2.3-2 Lifting Mechanism

The lifting mechanism is constructed of formed steel or tube sections making up a scissor-type assembly. The scissor assembly is raised and lowered by single-acting hydraulic lift cylinders with holding valves. A two-section pump, driven by an engine, provides hydraulic power to the lift cylinders.

#### 2.3-3 Platform

The platform is constructed of a tubular support frame, a skid-resistant “diamond plate” deck surface and 39” hinged guardrails with 6” toe boards and mid-rails. The platform can be entered from the rear through a spring returned gate with latch. The platform is also equipped with a manual extension platform. A 110V outlet is also located on the platform.

### 2.4 Serial Number Nameplate

The serial number nameplate, located at the rear of the aerial platform, lists the following:

- Model number
- Serial number
- Aerial platform weight
- Maximum drivable height
- Maximum capacities
- Maximum number of persons permissible on the platform
- Voltage
- System pressure
- Lift pressure
- Maximum platform height
- Maximum wheel load



## 2.5 Component Identification

The following descriptions are for identification, explanation and locating purposes only.

### 2.5-1 Emergency Main Power Disconnect Switch

This switch is located at the left side of the engine compartment.

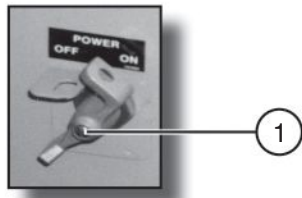

Figure 2-1. Emergency Main Power Disconnect Switch

1. **Emergency Main Power Disconnect Switch** - This switch, when in “○” off position, disconnects power to all circuits. Switch must be in “|” on position to operate any circuit. Turn switch “○” off when transporting aerial platform.

### 2.5-2 Motion Alarm

The alarm produces an audible sound when any control function is selected. On aerial platforms with certain options, a flashing amber light will accompany this alarm.

### 2.5-3 Tilt Alarm

The aerial platform is equipped with a device which senses when the aerial platform is out of level in any direction. When activated, it disables drive and lift functions of the aerial platform and an alarm produces an audible sound accompanied by the amber light. If the alarm sounds, lower the platform completely, then reposition aerial platform so that it is level before raising the platform.

#### NOTE

If the tilt alarm sounds and the platform does not, or only partially raises, immediately lower the platform completely and ensure that the aerial platform is on a firm level surface.

### 2.5-4 Brake System

The brake system is located on the main manifold in the hydraulic/fuel compartment. The brakes must be manually disengaged before pushing, winching or towing. Refer to [Section 2.15-2](#) for procedure on how to release the brakes manually. The system contains the following controls:

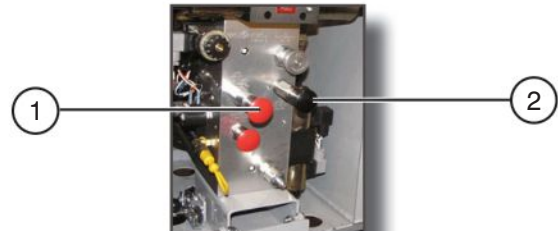

Figure 2-2. Brake System

1. Brake hand pump
2. Brake auto reset valve plunger

**2.5-5 Emergency Lowering System**

The emergency lowering system allows platform lowering in the event of an emergency or an electrical system failure. Refer to [Section 2.16](#) for the emergency lowering procedure. The system contains the following controls:

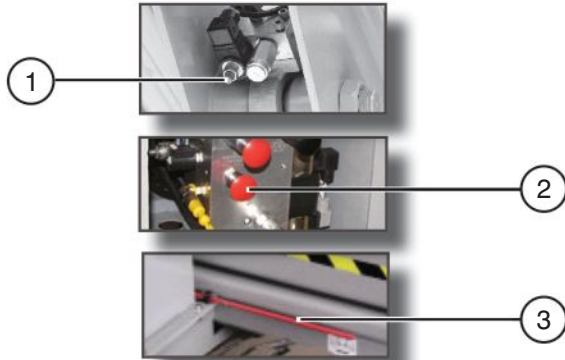

Figure 2-3. Emergency Lowering System

1. **Holding Valve Manual Override Knob** - Located on the holding valve at the bottom of each lift cylinder.
2. **Emergency Lowering Valve** - Located at the hydraulic/fuel compartment.
3. **Emergency Lowering Access Rod** - Located at the right side of the base.

**2.5-6 Free-wheeling Valve**



Figure 2-4. Free-wheeling Valve

1. **Free-wheeling Valve** - The free-wheeling valve is located on the main manifold in the hydraulic/fuel compartment. Refer to [Section 2.15-1](#) for procedure on how to release the free-wheeling valve.

**2.5-7 Propane Cylinder**

The propane cylinder is located on the base of the aerial platform. It has the following control:

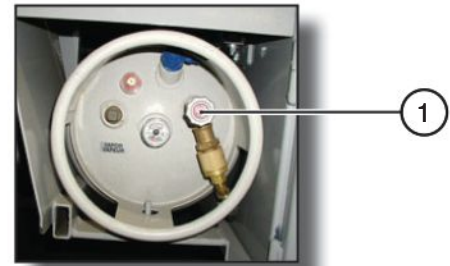

Figure 2-5. Propane Cylinder

1. **Cylinder Main Valve** - Turn this valve clockwise to shut off the fuel supply; counterclockwise to open it.



**2.5-8 Base Control Console**

The control console is located on the left side of the engine compartment. It contains the following controls:

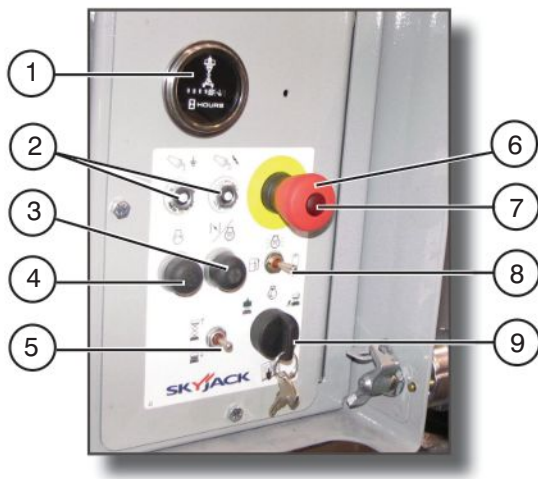

Figure 2-6. Base Control Console - Dual Fuel

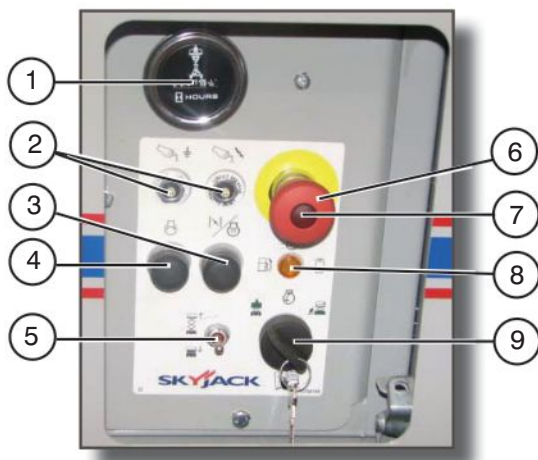

Figure 2-7. Base Control Console - Diesel

1. **Hourmeter** - This gauge records accumulated operating time of engine.
2. **Circuit Breakers** - In the event of a power overload or positive circuit grounding, the circuit breaker pops out. Push breaker back in to reset.
3. **Choke Pushbutton (Dual Fuel)** - This pushbutton switch aids in starting a cold dual-fuel engine.

**Glow Plug Pushbutton (Diesel)** - This pushbutton switch energizes the glow plugs to aid in starting a cold diesel engine.

4. **Engine Start Pushbutton** - This pushbutton “🔌” energizes the engine starter motor.
5. **Platform Raise/Lower Switch** - This switch controls “⬆️” raising or “⬇️” lowering of platform.
6. **Emergency Stop Button** - This button “🛑”, when depressed, disconnects power to control circuit and shuts engine off.
7. **Power Indicator Light** - When the emergency stop button on the base control console and on the platform control console are both pulled out, this light glows.
8. **Fuel Switch (Dual Fuel)** - Used to switch between “🔥” liquid propane gas and “⛽” gasoline.  
  
**Glow Plug Indicator Light (Diesel)** - This red lamp “🔴” illuminates until the glow plugs have completed their timed heating cycle. When the lamp goes out, the engine is ready to be started.
9. **Platform/Engine/Base Key Switch** - This three-way selector switch allows the operator to turn the “🔌” engine in an idling mode or to activate either the “🏠” base or “🏗️” platform controls.

### 2.5-9 Maintenance Support

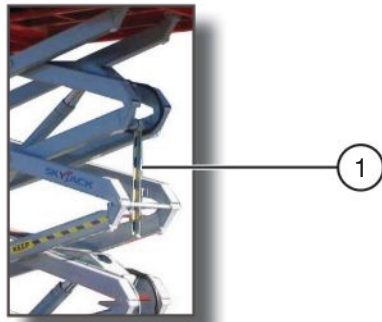

Figure 2-8. Maintenance Support

1. **Maintenance Support** - The maintenance support is a safety mechanism designed to support the scissor assembly. When properly positioned, it can support the scissor assembly and empty platform. The maintenance support must be used when inspection and/or maintenance is to be performed within the lifting mechanism. Refer to [Section 2.17](#) for how to use the maintenance support.



#### **WARNING**

**The maintenance support must be used when inspection and/or maintenance or repairs are to be performed within the lifting mechanism. Failure to use this safety mechanism could result in death or serious injury.**



#### **WARNING**

**Do not reach through the scissor assembly when the platform is raised without the maintenance support properly positioned. Failure to avoid this hazard could result in death or serious injury.**

### 2.5-10 Manual Storage Box

This weather-resistant box is mounted on the platform railings. It contains operating manual, ANSI manual of responsibility and ANSI/CSA certificate. The operating manual for this make and model of aerial platform must remain with the aerial platform and should be stored in this box.



**2.5-11 Platform Control Console**

This removable control console is mounted at the right front of the platform. It contains the following controls:

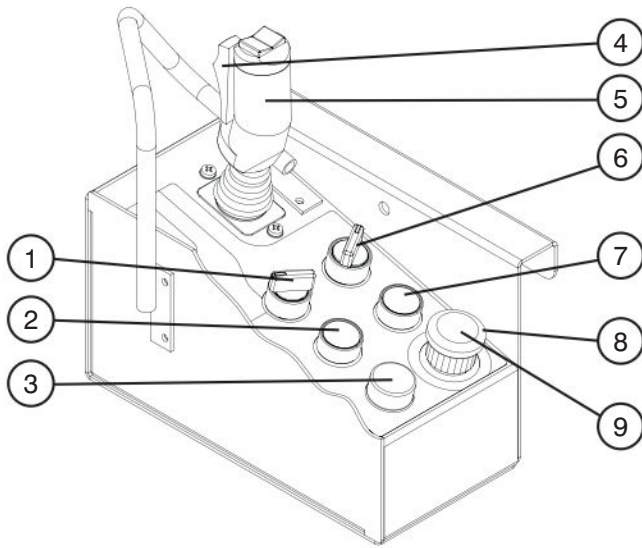

Figure 2-9. Platform Control Console

1. **Lift/Torque/Drive Switch** - This selector switch, when in “” lift position, allows lift functions to operate. When in “” low speed position, it allows drive functions to operate at low speed and maximum torque when climbing grades and on rough terrain. When in “” high speed position, it allows drive functions to operate at high speed with minimum torque.

2. **Engine Start Pushbutton** - This “” pushbutton energizes the engine starter motor.

**NOTE**

The engine start pushbutton is interlocked with the oil pressure switch. If engine stalls or does not start immediately, this button will not work for a few seconds while oil pressure bleeds off.

3. **Horn Pushbutton** - This “” pushbutton sounds an automotive-type horn.

4. **Lift/Drive/Steer Enable Trigger Switch** - This momentary “” switch energizes the controller. It must be held depressed continuously while engaging either the lift/drive or steer functions.

5. **Lift/Drive/Steer Controller** - This one-hand lever controls lift/drive and steer motions. Internal springs return it to neutral when controller is released. The rocker switch on top of controller handle controls steering function.

6. **Low/High Throttle Switch** - This rotary switch allows selection between “” low and “” high engine throttle speeds.

7. **Choke Pushbutton (Dual Fuel)** - This pushbutton sets the “” choke for starting a cold gasoline/propane engine.

**Glow Plug Pushbutton (Diesel)** - This pushbutton energizes the “” glow plugs to aid in starting a cold diesel engine.

8. **Emergency Stop Button** - This button “”, when depressed, disconnects power to the control circuit.

9. **Power Indicator Light** - This light glows when “” platform is selected from the platform/engine/base key switch on the base control console. It also glows when both emergency stop buttons on the platform control console and the base control console are pulled out.

**2.5-12 Folding Guardrail System**

This system, when folded down, reduces the height of the retracted aerial platform for transporting and traveling through doorways only. Refer to [Section 2.13](#) for guardrail folding procedure.



**WARNING**

The scissor assembly must be fully lowered before raising or lowering the guardrails.



**WARNING**

Any lowered guardrail will create a fall hazard. Remain away from the sides of the platform while raising or lowering the guardrails to avoid falling. Refer to [Section 2.13](#), for guardrail folding procedure.

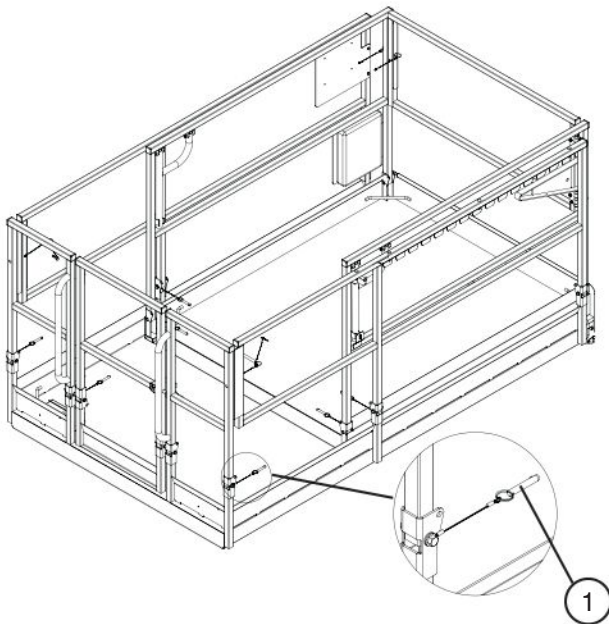

Figure 2-10. Folding Guardrail System

1. **Guardrail Locking Pin with Lanyard** - This pin is used to lock the guardrail in place.



**WARNING**

Before operating this aerial platform check the guardrail system for loose or missing locking pins. The guardrail system must be upright and all pins must be locked in place.

Death or serious injury could result if the guardrail system is not upright or properly locked.

**2.5-13 Safety Belt/Harness Attachment Bar**

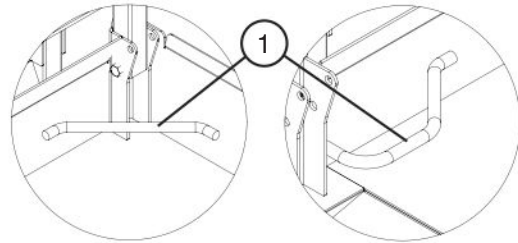

Figure 2-11. Safety Belt/Harness Attachment Bar

1. **Lanyard Attachment Anchorage** - Use this as an attachment point for safety belt/harness tethers. Do not attach belts/harnesses to any other point on the platform. Do not use this to lift, anchor, secure or support the platform or any other apparatus or material.



**WARNING**

The lanyard attachment anchorage is used for travel restraint, within the limits of the platform only. It is not a fall arresting device! Used as such could result in death or serious injury.

**2.6 Component Identification (Special Options)**

This section describes the components that are optional to aerial platforms.

**2.6-1 Outrigger/Generator Control Console (Auto-Leveling) (If Equipped)**

The outrigger/generator control console is located next to the platform control console. These switches control the generator, and outriggers' extension and retraction.

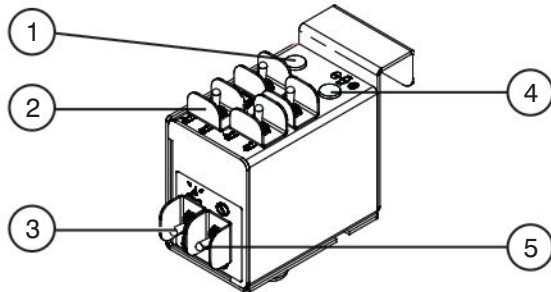









Figure 2-12. Outrigger/Generator Control Console with All Options

1. **Generator Switch** - This switch activates the generator.
2. **Outrigger Extend/Retract Switches** - These switches control the extension or retraction of each individual outrigger.
3. **Auto-Level Switch** - In the “” extend position, each outrigger extends and automatically adjusts until aerial platform is level. In the “” retract position, the outriggers retract.
4. **Outrigger Enable Switch** - This “” outrigger enable switch, when in the extend or retract position, activates functions on the auto-level switch and outrigger extend/retract switches.

5. **Leveling Indicator Light** - This light illuminates to display the status of the outriggers when the auto and manual level functions are in use. The indicator light has the following states:

-  **Off:** The outriggers are fully retracted.
-  **Flashing Rapidly:** The outriggers are extending but the platform is not level.
-  **Flashing:** The outriggers are extended but the platform is not yet level.
-  **Solid:** The outriggers are extended and the platform is level.

**2.6-2 800W AC Inverter (If Equipped)**

The inverter is located on the base of the aerial platform. It has the following controls:

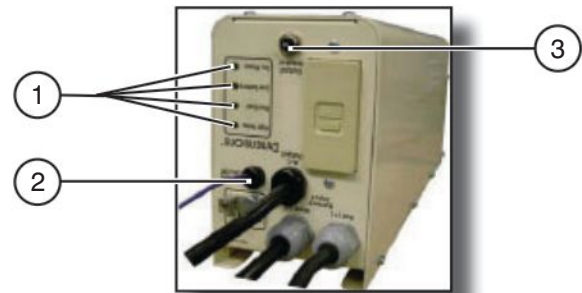

Figure 2-13. 800W AC Inverter

**NOTE**

The inverter operation is automatic. These controls do not need to be manipulated for normal operation.

1. **Status LEDs** - These LEDs indicate the operating or fault status of the inverter.
2. **On/Off Wire** - This wire is the connection to turn the inverter on.
3. **15 Amp Circuit Breaker** - In the event of a power overload or circuit grounding, the circuit breaker will pop out. Ensure the overload is removed. Push the breaker back in to reset.
4. **GFCI Outlet** - During inverter operation, this outlet provides AC power.



### 2.6-3 Tire Sealant (If Equipped)

This option is identified with a tire sealant label located at the rim of the wheel.

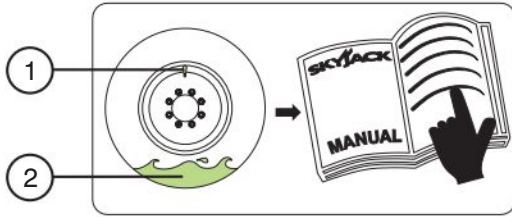

Figure 2-14. Tire Sealant Label

**Tire Sealant Label** - This label indicates that tire sealant is present inside the tires.

1. **Tire Valve Stem Cap** - This green valve stem cap is substituted onto air tires to indicate sealant has been installed.
2. **Sealant** - This symbol signifies that the tire is equipped with sealant.



#### **WARNING**

The operator **MUST** properly handle tires with sealant.

- When depressurizing, inflating or checking tire pressure, ensure that the valve stem is at the top to prevent sealant from entering the stem (refer to Figure 2-14).
- If the tire no longer holds pressure, replace the tire.



#### **WARNING**

The sealant contains propylene glycol. Do not ingest, inhale or get into eyes. If it gets into your eyes, flush with water for 15 minutes. Consult physician.

## 2.7 Operator's Responsibility

It is the responsibility of the operator, prior to each work shift, to perform the following:

### 1. Visual and Daily Maintenance Inspections

- are designed to discover any damage of components before the aerial platform is put into service.
- are done before the operator performs the function tests.



#### **WARNING**

**Failure to locate and repair damage, and discover loose or missing parts may result in an unsafe operating condition.**

### 2. Function Tests

- are designed to discover any malfunctions before the aerial platform is put into service.

#### **IMPORTANT**

**The operator must understand and follow the step-by-step instructions to test all aerial platform functions.**

The operator should make a copy of the Operator's Checklist (see [Table 2.7](#)) and fill out the visual and daily maintenance inspections and the function tests sections while performing the items outlined in [Section 2.8](#) and [Section 2.9](#).

#### **IMPORTANT**

**If aerial platform is damaged or any unauthorized variation from factory-delivered condition is discovered, aerial platform must be tagged and removed from service.**

Repairs to the aerial platform may only be made by a qualified service technician. After repairs are completed, the operator must perform visual and daily maintenance inspections & function tests again.

Scheduled maintenance inspections shall only be performed by qualified service technician (see [Table 2.6](#)).

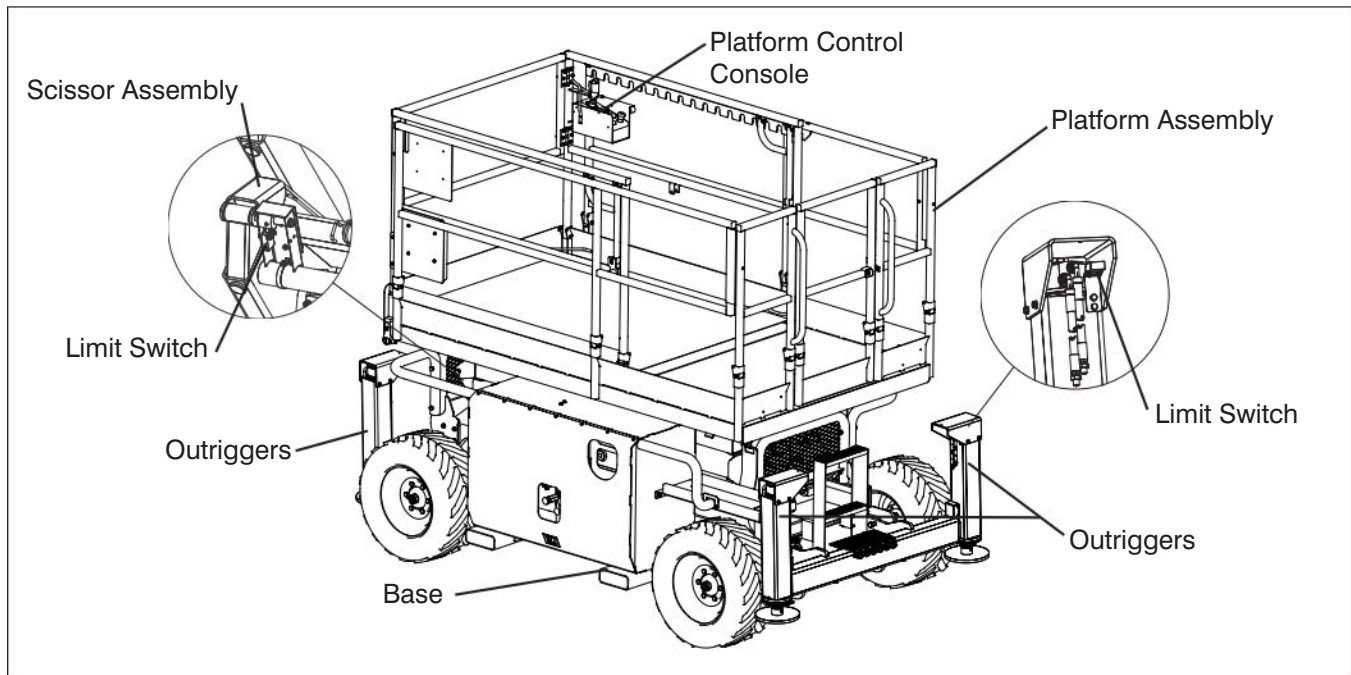

## 2.8 Visual & Daily Maintenance Inspections

Begin the visual and daily maintenance inspections by checking each item in sequence for the conditions listed in this section.



### **WARNING**

**To avoid injury, do not operate an aerial platform until all malfunctions have been corrected.**



### **WARNING**

**To avoid possible injury, ensure aerial platform power is off during your visual and daily maintenance inspections.**

### **NOTE**

While doing visual and daily inspections in different areas, be aware to also inspect limit switches, electrical and hydraulic components.

#### 2.8-1 Labels

Refer to the labels section in this manual and determine that all labels are in place and are legible.

#### 2.8-2 Electrical

Maintaining the electrical components is essential to good performance and service life of the aerial platform.

Inspect the following areas for chafed, corroded and loose wires:

- base to platform cables and wiring harness
- engine compartment electrical panel
- engine wiring harness
- hydraulic/electrical wiring harnesses

#### 2.8-3 Limit Switches

Ensure limit switches are properly secured with no signs of visible damage and movement is not obstructed.

#### 2.8-4 Hydraulic

Maintaining the hydraulic components is essential to good performance and service life of the aerial platform.

Perform a visual inspection around the following areas:

- hydraulic tank filter, fittings, hoses, emergency power unit (if equipped) and base surfaces
- engine compartment fittings, hoses, main pump, and filter
- all hydraulic cylinders
- all hydraulic manifolds
- the underside of the base
- ground area under the aerial platform
- outriggers



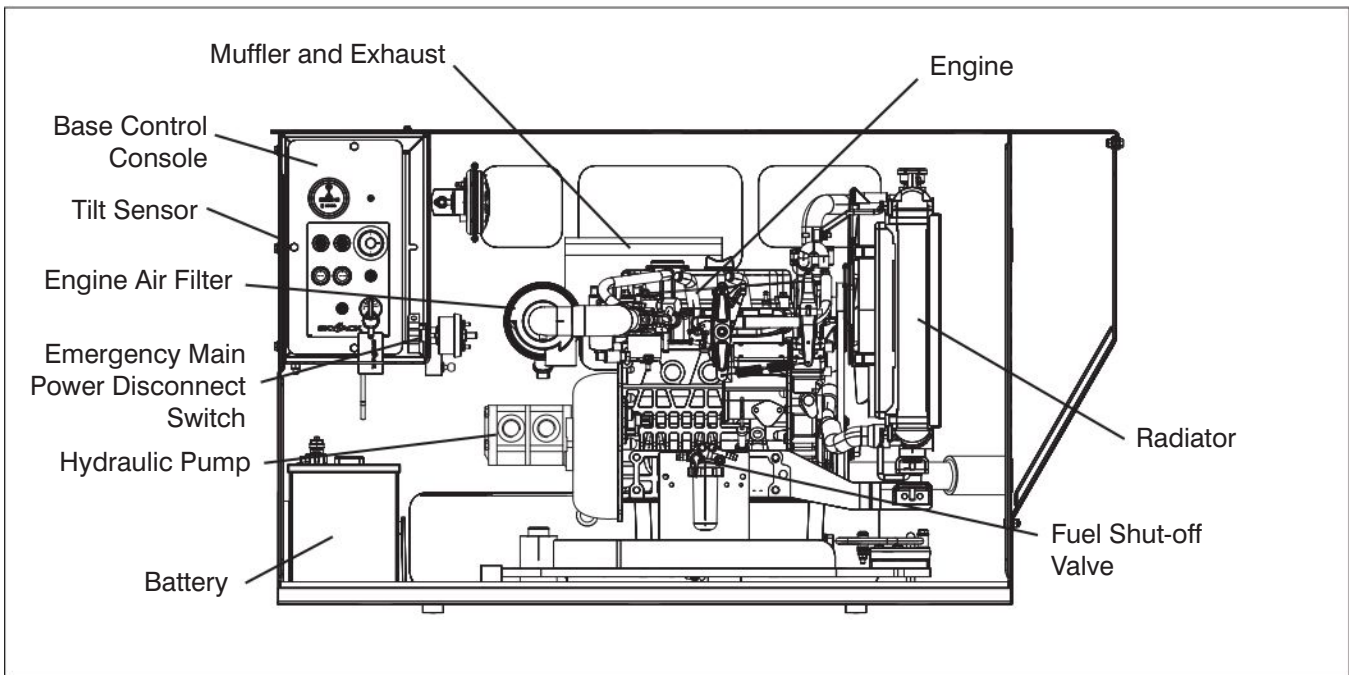

**2.8-5 Engine Compartment**

- Ensure compartment latch is secure and in proper working order.
- **Emergency Main Power Disconnect Switch**
  - Turn emergency main power disconnect switch to “O” off position.
  - Ensure all cables are secure and switch is in proper working condition.
- **Base Control Switches**
  - Ensure there are no signs of visible damage and all switches are in their neutral positions.
- **Tilt Sensor**
  - Ensure tilt sensor is properly secure and there is no visible damage.
- **Battery**

Proper battery condition is essential to good performance and operational safety. Improper fluid levels or damaged cables and connections can result in component damage and hazardous conditions.



**WARNING**

**Battery acid is extremely corrosive - Wear proper eye and facial protection as well as appropriate protective clothing. If contact occurs, immediately flush with cold water and seek medical attention.**

1. Check battery case for damage.
2. Clean battery terminals and cable ends thoroughly with a terminal cleaning tool or wire brush.
3. Ensure all battery connections are tight.
4. If applicable, check battery fluid level. If plates are not covered by at least 1/2” (13 mm) of solution, add distilled or demineralized water.
5. Replace battery if damaged or incapable of holding a lasting charge.



**WARNING**

**Use original or manufacturer-approved parts and components for the aerial platform.**



**WARNING**

**Explosion hazard. Keep flames and sparks away. Do not smoke near batteries.**



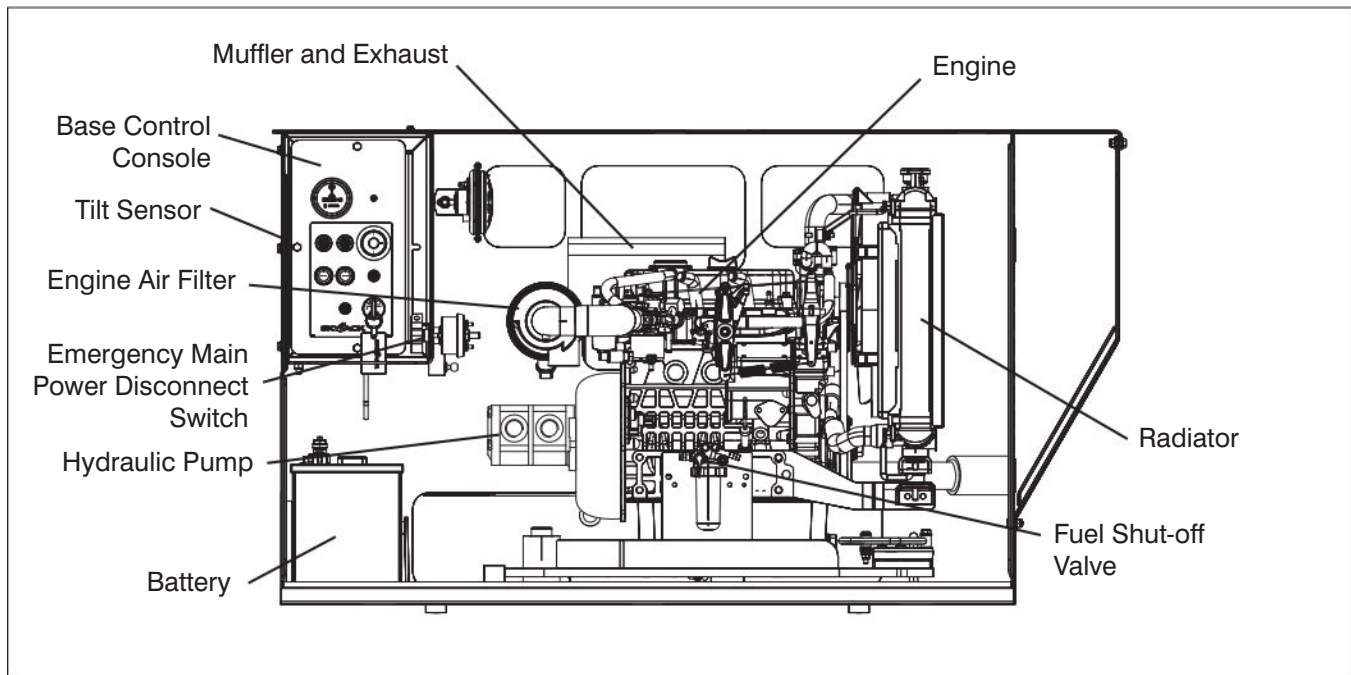

- **Hydraulic Pump**

- Ensure there are no loose or missing parts and there is no visible damage.
- Ensure all bolts are properly tightened.
- Ensure all fittings and hoses are properly tightened and there is no evidence of hydraulic leakage.

- **Radiator**

- Ensure radiator is secure.
- Ensure there are no loose or missing parts and there is no visible damage.
- Check coolant level and add as needed.

- **Muffler and Exhaust**

- Ensure muffler and exhaust system are properly secured, with no evidence of damage.

- **Engine Pivot Tray**

- Ensure there are no loose or missing parts and no visible damage to the engine pivot tray. Ensure that both tray-securing bolts are in place.

- **Engine Oil Level**

- Maintaining the engine components is essential to good performance and service life of the aerial platform.



**WARNING**

**Beware of hot engine components.**

**Check oil level on dipstick**

- Oil level should be in the "safe" zone. Add oil as needed.

- **Fuel Shut-off Valve**

- Ensure there are no loose or missing parts and there is no visible damage.

- **Engine Air Filter**

- Ensure there are no loose or missing parts and there is no visible damage.

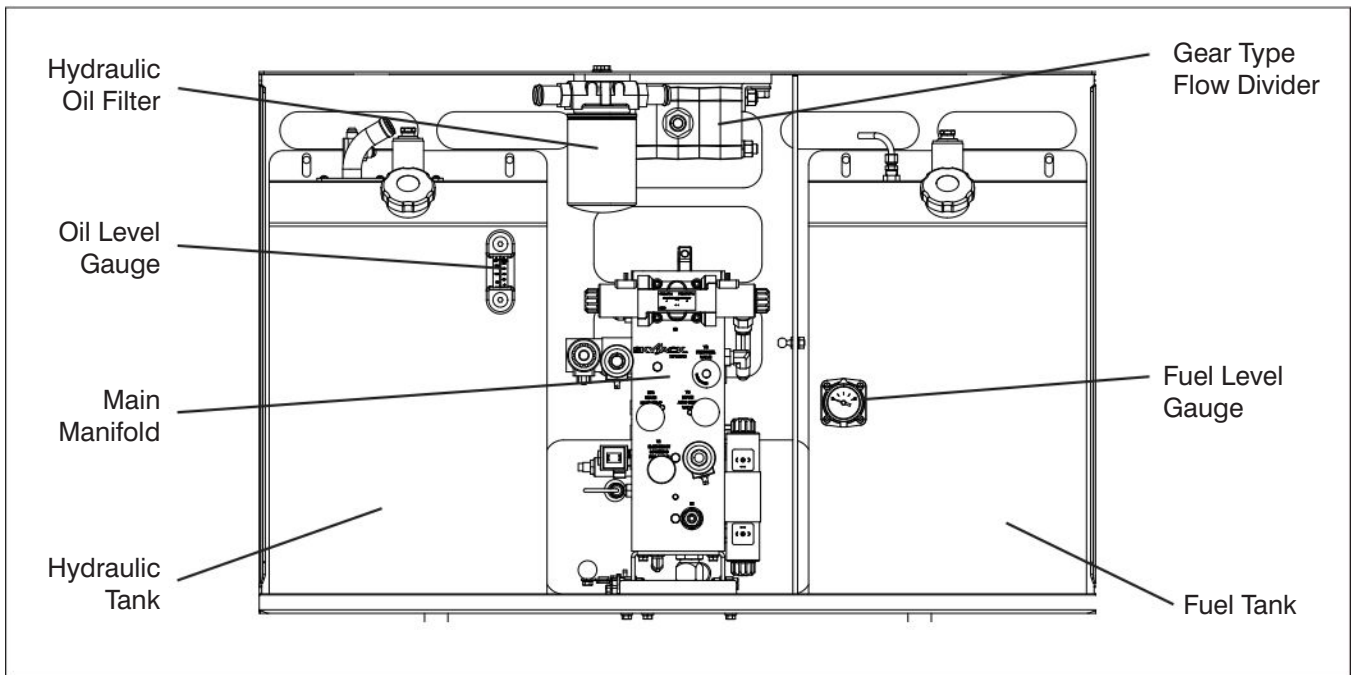

- Fuel Leaks**  
 Failure to detect and correct fuel leaks will result in an unsafe condition. An explosion or fuel fire may cause death or serious injury.



**Engine fuels are combustible. Inspect the aerial platform in an open, well-ventilated area away from heaters, sparks and flames. Always have an approved fire extinguisher within easy reach.**

Perform a visual inspection around the following areas:

- hoses and fittings
- fuel pump
- fuel filter

**2.8-6 Hydraulic/Fuel Compartment**

- Ensure compartment latch is secure and in proper working order.
- Hydraulic Tank**
  - Ensure hydraulic filler cap is secure.
  - Ensure tank shows no visible damage and no evidence of hydraulic leakage.
- Hydraulic Oil**
  - Ensure platform is fully lowered, and then visually inspect the sight gauge located on the side of the hydraulic oil tank.
  - The hydraulic oil level should be at or slightly above the top mark of the sight glass.
- Hydraulic Return Filter**
  - Ensure filter element is secure.
  - Ensure there are no signs of leakage or visible damage.

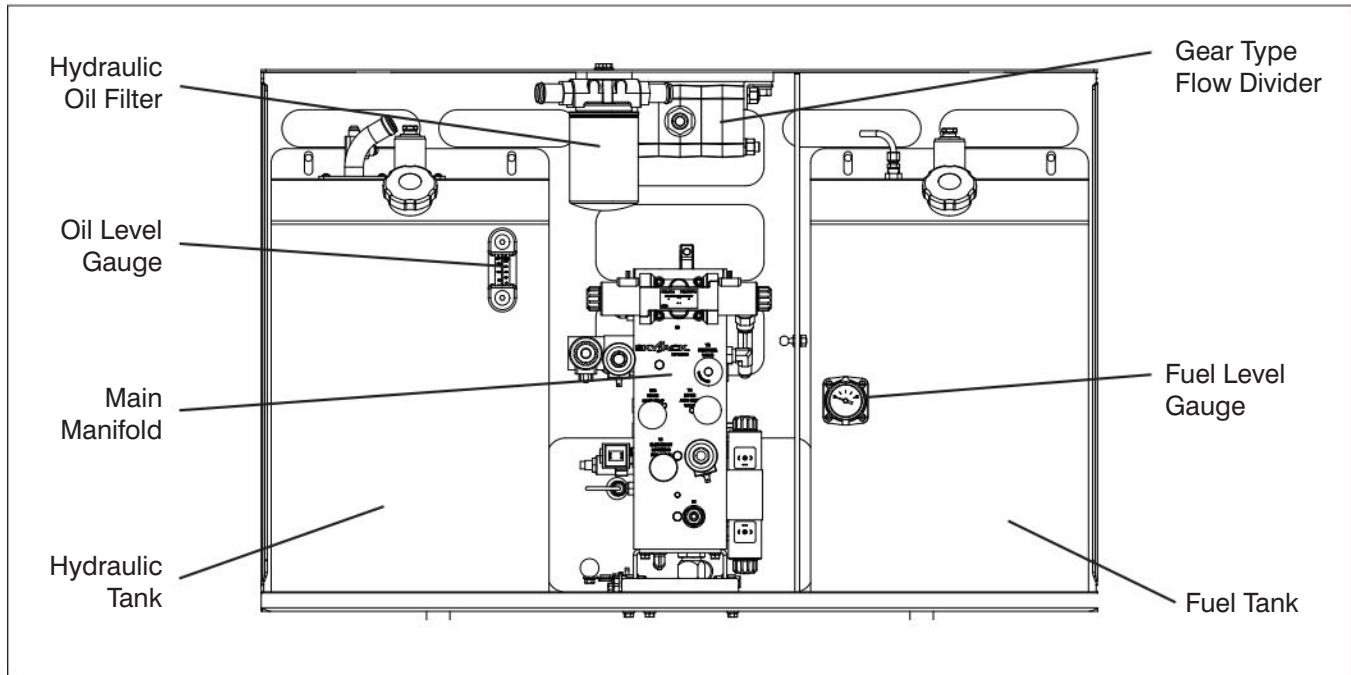

- **Fuel Tank**

**IMPORTANT**

**Before using your aerial platform ensure there is enough fuel for expected use.**

- Ensure fuel filler cap is secure.
- Ensure tank shows no visible damage and no evidence of fuel leakage.

- **Fuel Leaks**

Failure to detect and correct fuel leaks will result in an unsafe condition. An explosion or fuel fire may cause death or serious injury.



**DANGER**

**Engine fuels are combustible. Inspect the aerial platform in an open, well-ventilated area away from heaters, sparks and flames. Always have an approved fire extinguisher within easy reach.**

Perform a visual inspection around the following areas:

- fuel tank
- hoses and fittings

- **Main Manifold**

- Ensure all fittings and hoses are properly tightened and there is no evidence of hydraulic leakage.
- Ensure there are no loose wires or missing fasteners.

- **Gear Type Flow Divider**

- Ensure there are no loose or missing parts and there is no visible damage.

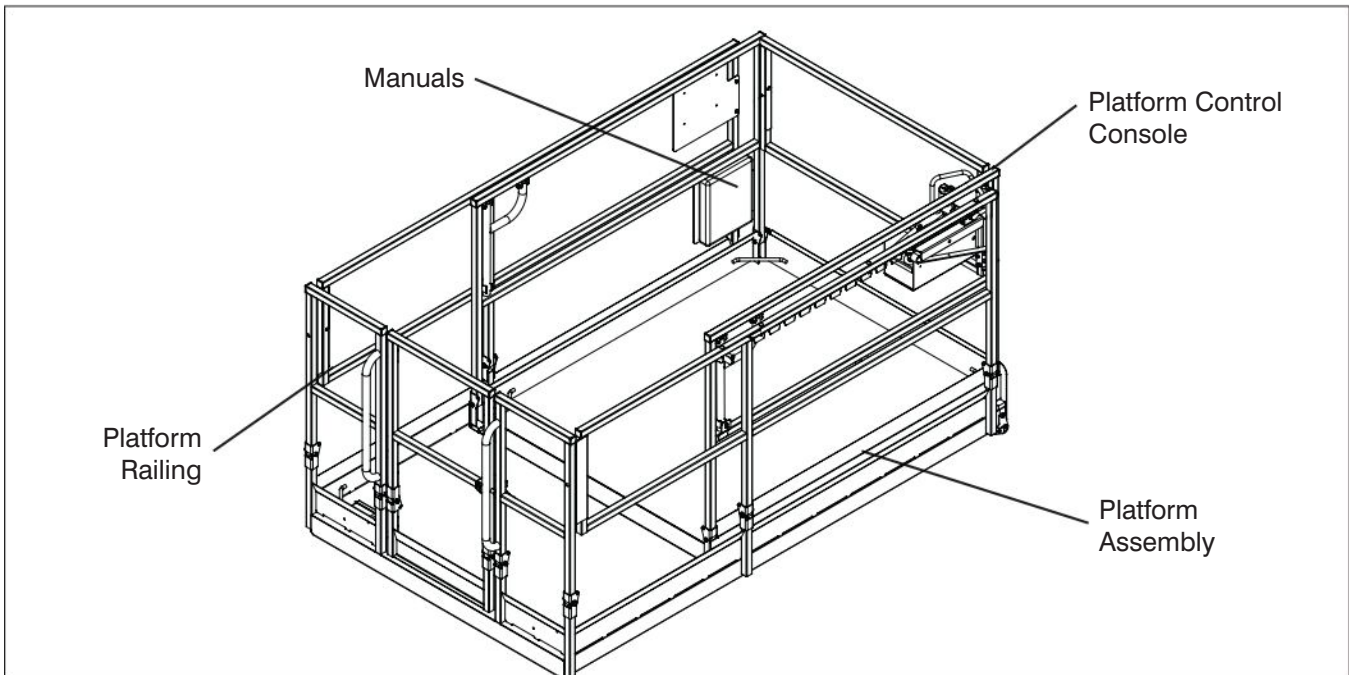

**2.8-7 Platform Assembly**



**WARNING**

**Ensure that you maintain three points of contact to mount/dismount platform.**

1. Use the ladder of aerial platform to platform.
2. Close the gate.
  - Ensure there are no loose or missing parts and there is no visible damage.
  - Ensure all fasteners are securely in place.
  - Ensure all railings are properly positioned and secured.
  - Ensure gate is in good working order.
- **Lanyard Attachment Anchors**
  - Ensure attachment rings are secure and no visible damage.

- **AC Outlet on Platform**
  - Ensure outlet has no visible damage and free from dirt or obstructions.
- **Manuals**

Ensure a copy of operating manual, manual of responsibilities and ANSI/CSA certificate are enclosed in manual storage box.

  - Check to be sure manual storage box is present and in good condition.
  - Ensure manuals are legible and in good condition.
  - Always return manuals to the manual storage box after use.
- **Platform Control Console**
  - Ensure all switches and controller are returned to neutral and are properly secured.
  - Ensure there are no loose or missing parts and there is no visible damage.



**WARNING**

**Ensure that you maintain three points of contact to mount/dismount platform.**

3. Use the ladder to dismount from platform.



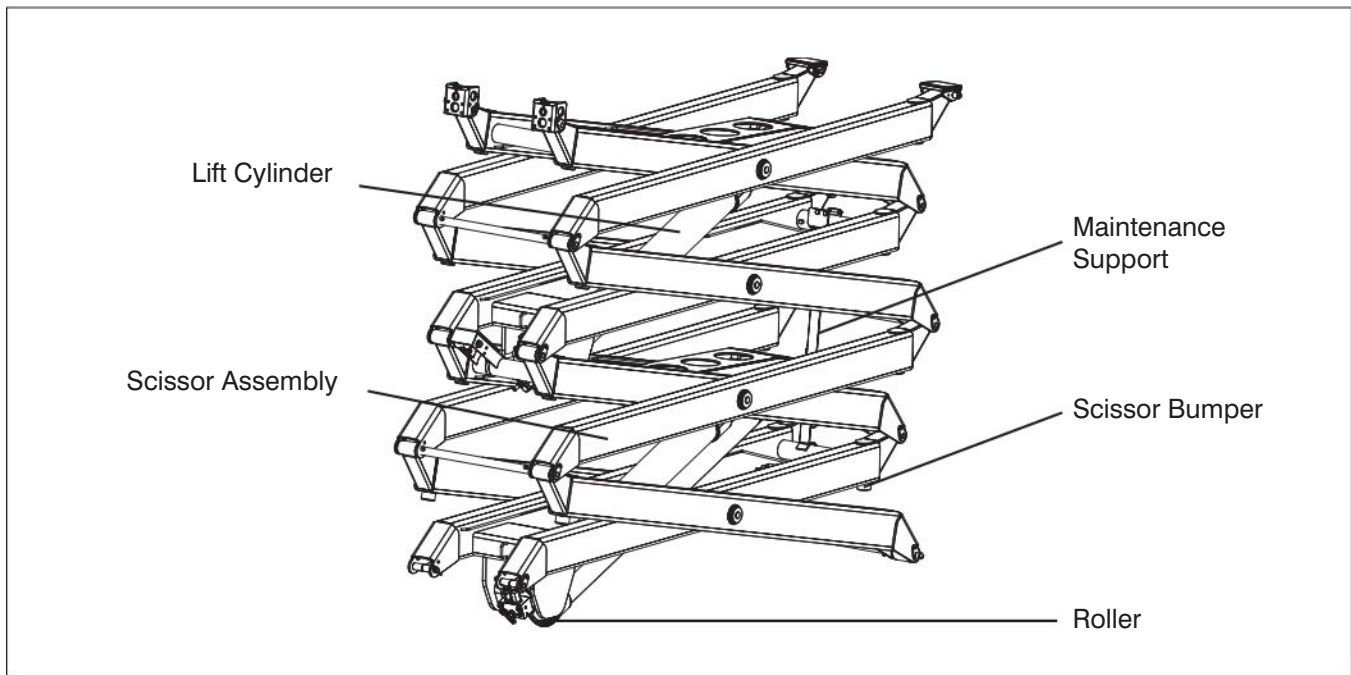

### 2.8-8 Lifting Mechanism

1. Raise the platform (refer to [Section 2.10-2](#)) until there is adequate clearance to swing down the maintenance support (refer to [Section 2.16](#)).

- **Maintenance Support**

- Ensure maintenance support is properly secured and shows no visible damage.

- **Scissor Assembly**

- Ensure scissor assembly shows no visible damage and no signs of deformation in weldments.
- Ensure all pins are properly secured.
- Ensure cables and wires are properly routed and shows no signs of wear and/or physical damage.

- **Scissor Bumpers**

- Ensure bumpers are secure and shows no sign of visible damage.

- **Rollers**

- Ensure rollers are secure and there is no visible damage.
- Ensure rollers' path of travel are free from dirt and obstructions.

- **Lift Cylinder(s)**

- Ensure each lift cylinder is properly secured, there are no loose or missing parts and there is no evidence of damage.
- Ensure all fittings and hoses are properly tightened and there is no evidence of hydraulic leakage.

2. Raise the platform until there is adequate clearance to swing up the maintenance support into storage bracket. Refer to [Section 2.17](#)

3. Fully lower the platform.

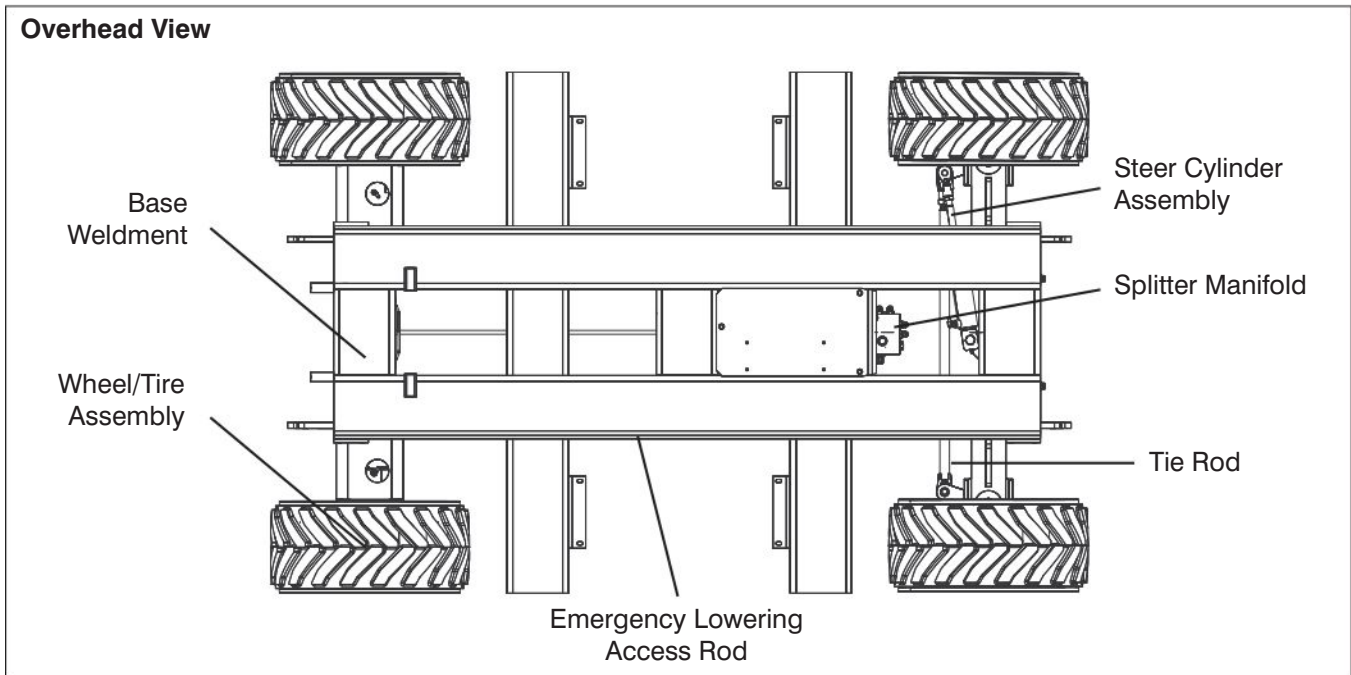

**2.8-9 Base**

- **Base Weldment**
  - Ensure there are no visible cracks in welds or structure and there are no signs of deformation.
- **Wheel/Tire Assembly**

The aerial platform is either equipped with air tires or foam-filled tires. Tire and/or wheel failure could result in an aerial platform tipover. Component damage may also result if problems are not discovered and repaired in a timely fashion.



**Air filled tires are not permitted on some models. Refer to Table 2.2.**



**An over-inflated tire can explode and may cause death or serious injury.**

- Check all tire treads and sidewalls for cuts, cracks, punctures and unusual wear.
- Check each wheel for damage and cracked welds.
- Check each lug nut for proper torque to ensure none are loose.
- Check wheel motor assembly for loose or missing parts and signs of visible damage.
- Ensure wheels are aligned and true vertically and horizontally.

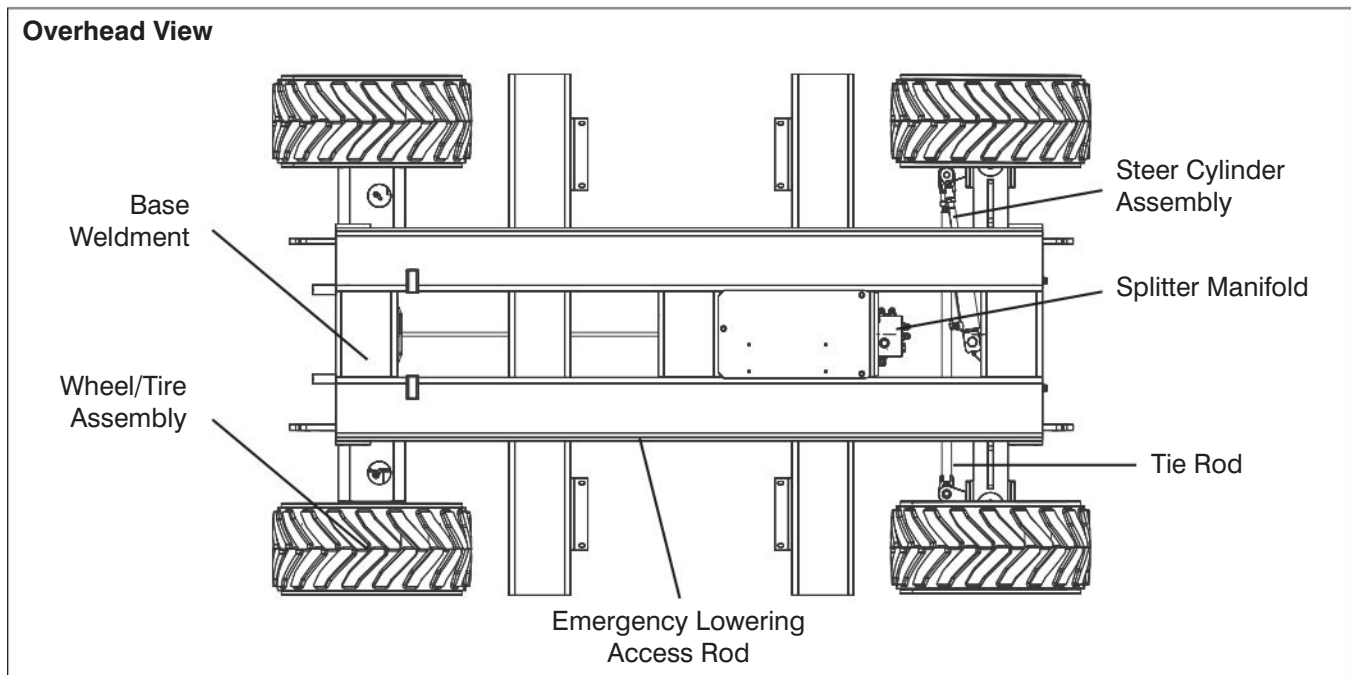

To safeguard maximum stability, achieve optimum aerial platform handling and minimize tire wear, it is essential to maintain proper pressure in all air-filled tires.

- Check each tire with an air pressure gauge and add air as needed.

Refer to [Table 2.2](#) for wheel/tire specifications.

- **Steer Cylinder Assembly**
  - Ensure steer cylinder assembly is properly secured, there are no loose or missing parts, all fittings and hoses are properly tightened and there is no evidence of hydraulic leakage.
- **Splitter Manifold**
  - Ensure all fittings and hoses are properly tightened and there is no evidence of hydraulic leakage.

- **Tie Rod**
  - Ensure there are no loose or missing parts, tie rod end studs are locked and there is no visible damage.
- **Emergency Lowering Access Rod**
  - Ensure rod is properly secured and there is no visible damage.
- **Ladder**
  - Ensure there are no loose or missing parts and there is no visible damage.
- **Outriggers**
  - Ensure there are no loose or missing parts and there is no visible damage.



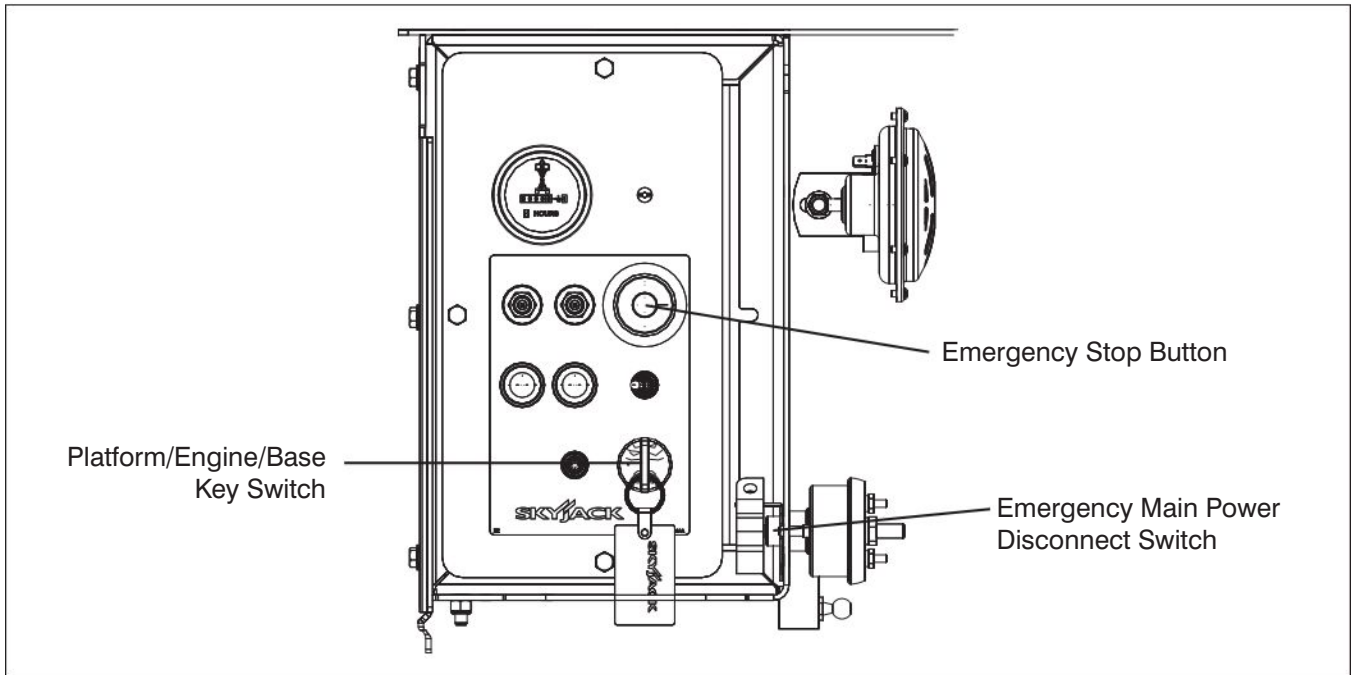

**2.9 Function Tests**

Function tests are designed to discover any malfunctions before aerial platform is put into service. The operator must understand and follow step-by-step instructions to test all aerial platform functions.

**IMPORTANT**

**Never use a malfunctioning aerial platform. If malfunctions are discovered, aerial platform must be tagged and placed out of service. Repairs to aerial platform may only be made by a qualified service technician.**

After repairs are completed, operator must perform a pre-operation inspection and a series of function tests again before putting aerial platform into service.

Prior to performing function tests, be sure to read and understand [Section 2.10](#) - Start Operation.

**2.9-1 Test Emergency Main Power Disconnect Switch**

1. In engine compartment, turn emergency main power disconnect switch to “○” off position.  
**Result:** Aerial platform functions should not operate.

**2.9-2 Base Control Console**



**Ensure that you maintain three points of contact when using the ladder to mount/dismount platform.**

1. Use the ladder of aerial platform to access platform.
2. Close the gate.
3. On platform control console, pull out “●” emergency stop button.
4. Select low/high throttle switch to “⊖” low throttle position.
5. Use the ladder to dismount from platform.
6. Turn emergency main power disconnect switch to “|” on position.

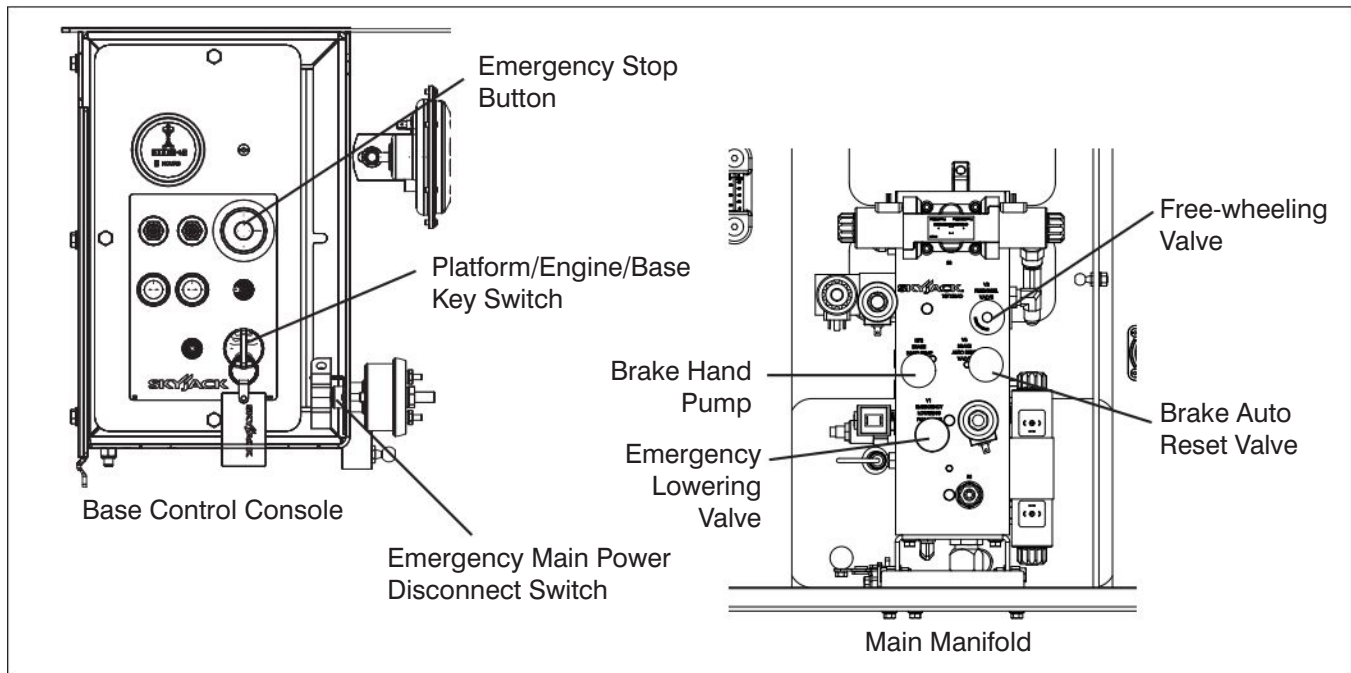



- **Test Platform/Engine/Base Key Switch**





**WARNING**



Be aware of overhead obstructions or other possible hazards around the aerial platform when lifting.

1. Pull out base “” emergency stop button.
2. Insert key into platform/engine/base key switch, select “” engine position and attempt to start engine.  
**Result:** Engine should not start.
3. With key inserted into platform/engine/base key switch, select “” base position and attempt to start engine.  
**Result:** Engine should start.

- **Test Emergency Stop**

1. Push in base “” emergency stop button.  
**Result:** Engine should shut down and aerial platform functions should not operate.
2. Pull out base “” emergency stop button and restart engine.

- **Test Platform Raise/Lower Switch**

1. Select platform/engine/base key switch to “” base position and raise or lower the platform with platform “” raise or “” lower switch.  
**Result:** Platform raising and lowering functions should operate.

- **Test Emergency Lowering**

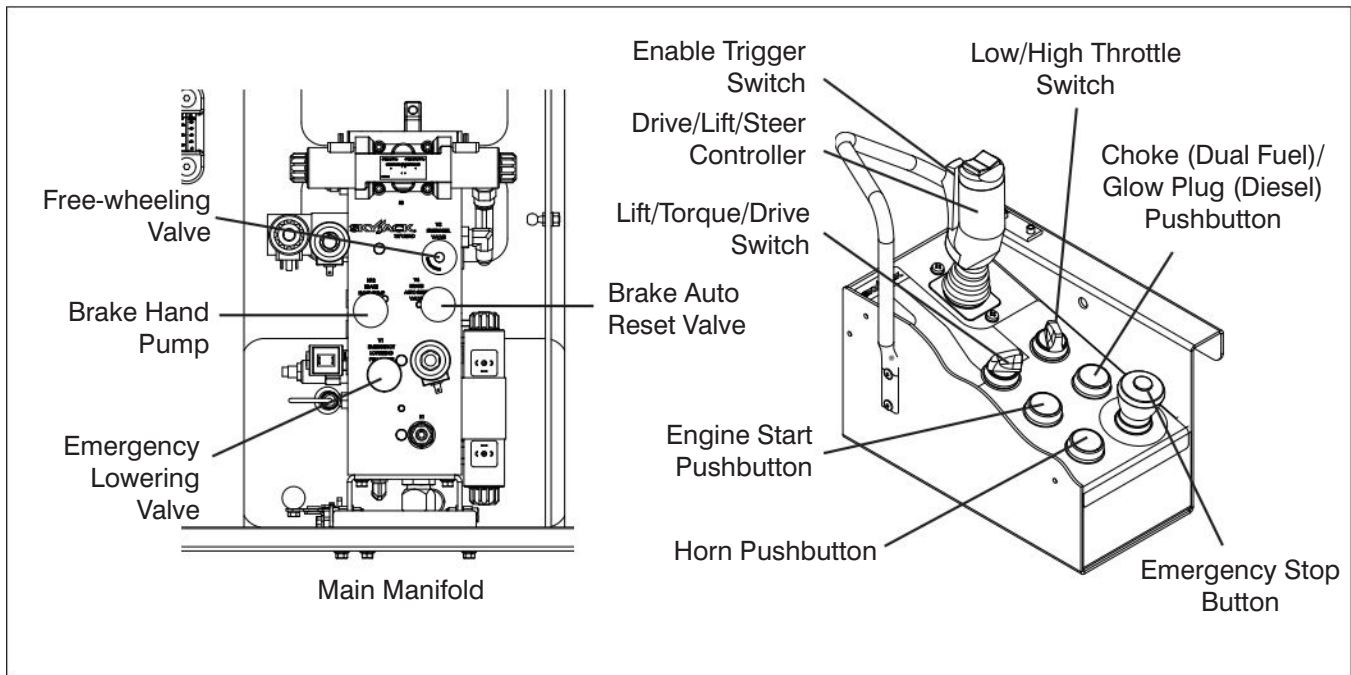

1. Raise the platform.
2. Locate holding valve manual override knob at the base of each lift cylinder. Depress and turn counterclockwise. If necessary, use access rod that is located on the base of the aerial platform.
3. On hydraulic/fuel compartment, pull out and hold emergency lowering valve to fully lower the platform.  
**Result:** The platform should lower.
4. To restore normal operation, depress and turn holding valve manual override knobs clockwise.



• **Test Free-wheeling**

1. Ensure path of intended motion is clear.
2. Release the brake manually (refer to [Section 2.15-2](#)).
3. Turn free-wheeling valve knob counterclockwise to a fully opened position and attempt to push/pull the aerial platform.  
**Result:** Aerial platform should move.
4. Turn free-wheeling valve knob clockwise to a fully closed position for normal operation.
5. Reengage the brake (refer to [Section 2.15-2](#)).

**2.9-3 Platform Control Console**

1. Ensure base “” emergency stop button is pulled out.
2. Ensure emergency main power disconnect switch is in “I” on position.
3. Select platform/engine/base key switch to  “” platform position and remove key.

 **WARNING**

**Ensure that you maintain three points of contact when using the ladder to mount/dismount platform.**

3. Use the ladder of aerial platform to access platform.
4. Close the gate.
5. On platform control console, pull out “” emergency stop button.

• **Test Emergency Stop**

1. Ensure engine is running.
2. Push in “” emergency stop button.  
**Result:** Engine should shut down and aerial platform functions should not operate.

• **Test Enable Trigger Switch**

1. Ensure engine is running.
2. Without activating “” enable trigger switch, attempt to activate any platform function.  
**Result:** All platform functions should not operate.

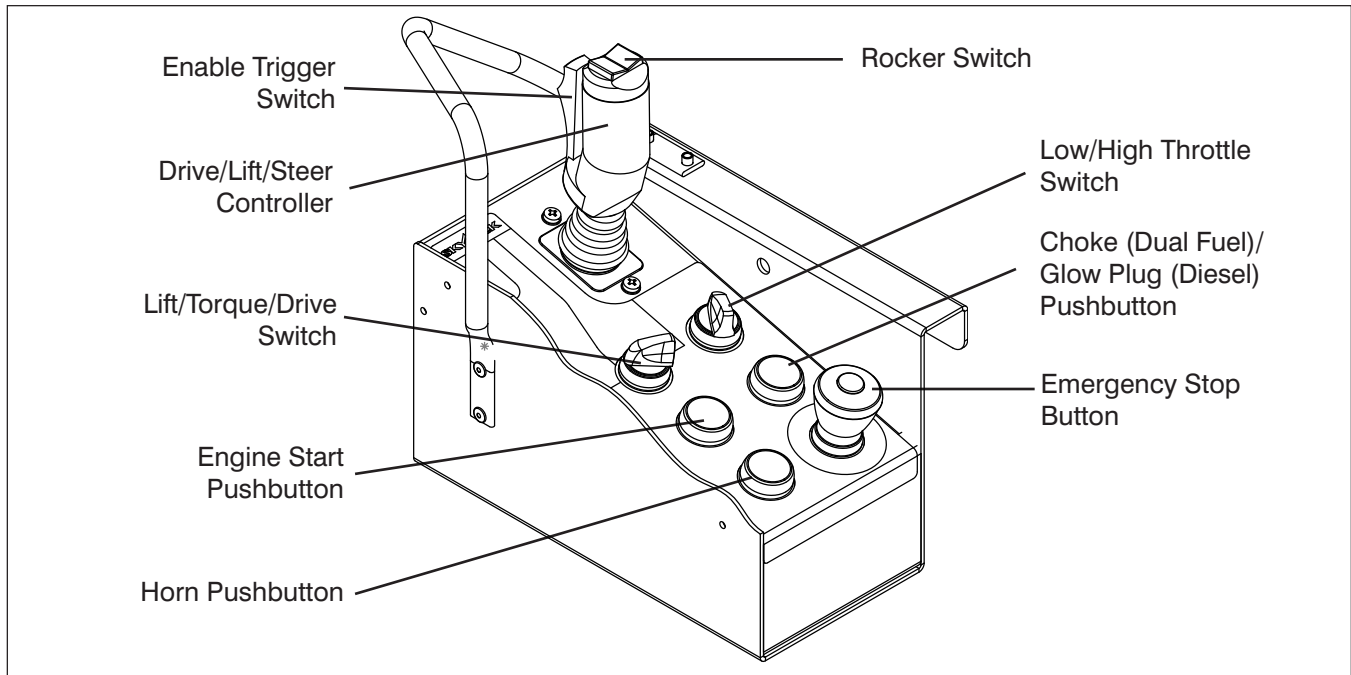



• **Test Platform Raising/Lowering**





**WARNING**

**Be aware of overhead obstructions or other possible hazards around the aerial platform when lifting.**

1. Select lift/torque/drive switch to “” lift position.
2. Activate and hold “” enable trigger switch.
3. Push or pull controller handle until desired height is reached.



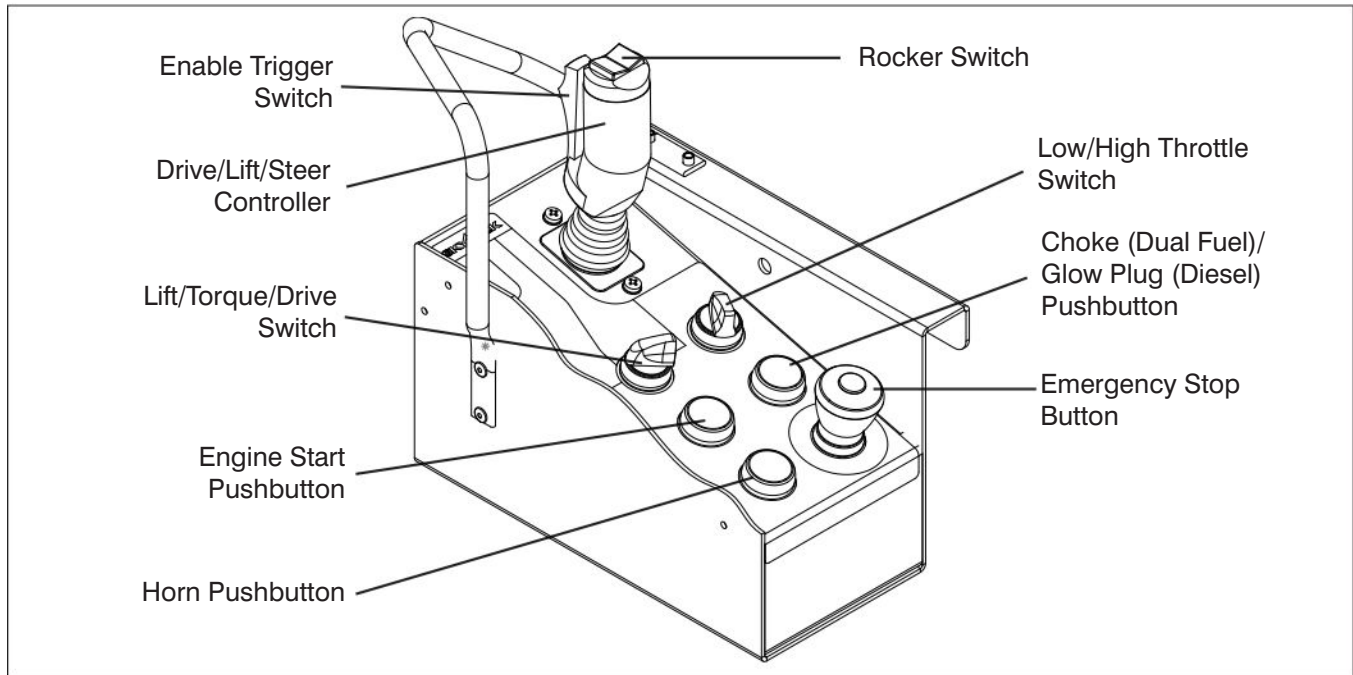

**Result:** Platform raising and lowering functions should operate.

• **Test Steering**

1. Ensure engine is running.
2. Press rocker switch on top of controller to “” left and “” right.  
**Result:** Steer wheels should turn left and right.



• **Test Driving**

1. Ensure path of intended motion is clear.
2. On platform control console, select lift/lift/steer controller to “” drive position.
2. Activate and hold “” enable trigger switch.
3. Slowly move controller in “” forward or “” reverse direction until aerial platform begins to move, and then return handle to center position.

**Result:** Aerial platform should move in forward or reverse direction, and then come to a stop.

• **Test Speed Limit**



**WARNING**

**Be aware of overhead obstructions or other possible hazards around the aerial platform when lifting.**

1. Ensure path of intended motion is clear.
2. Raise the platform until approximately a height of 7 feet (2 meters) is reached and attempt to drive forward or reverse.  
**Result:** Aerial platform should move slower than when it is in stowed position.

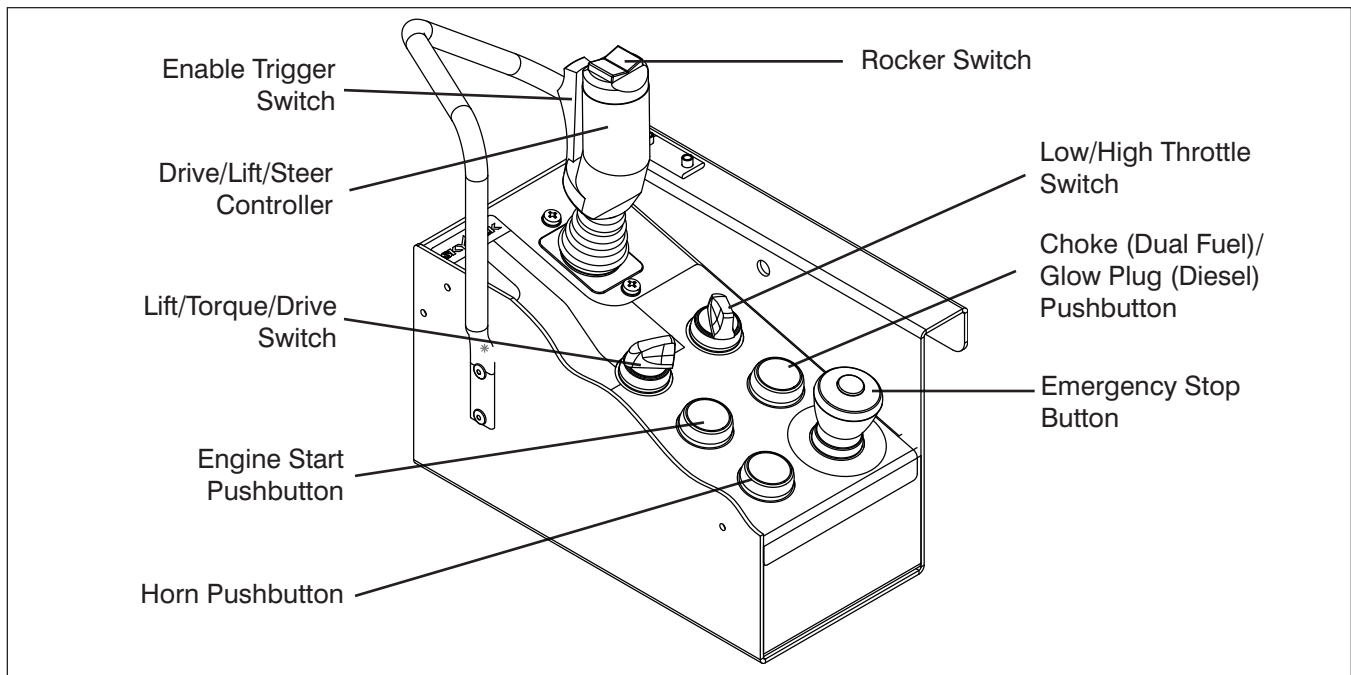





• **Test Brakes**



**WARNING**

**Brakes will engage instantly when you release the controller handle, causing aerial platform to stop immediately.**

1. Ensure path of intended motion is clear.
2. Activate and hold “” enable trigger switch.
3. Drive aerial platform “” forward. Test brake by releasing controller handle.  
**Result:** Aerial platform should come to a stop. If aerial platform pulls to one side while stopping, do not operate aerial platform until brake adjustments have been checked.
4. Drive aerial platform “” forward. Test brake again by releasing “” enable trigger switch only.  
**Result:** Aerial platform should come to an instant and abrupt stop. If aerial platform does not stop immediately, or if aerial platform pulls to one side while stopping, do not operate aerial platform until brake adjustments have been checked.

• **Test Horn**

1. Push “” horn pushbutton.  
**Result:** Horn should sound.

## 2.10 Start Operation

Carefully read and completely understand the operating manual and all warnings and instruction labels (refer to labels section) on the aerial platform.



### **WARNING**

**Do not operate this aerial platform without proper authorization and training. Failure to avoid this hazard could result in death or serious injury.**

Before operating this aerial platform, perform the following steps:

1. Visual and daily maintenance inspections (see [Section 2.8](#))
2. Function tests (see [Section 2.9](#))
3. Jobsite inspection  
It is the responsibility of the operator to perform a jobsite inspection and avoid the following hazardous situations:
  - holes or drop-offs
  - ditches or soft fills
  - floor obstructions, bumps or debris
  - overhead obstructions
  - electrical cords, hoses and high voltage conductors
  - hazardous locations
  - inadequate surface support to withstand all load forces imposed by the aerial platform
  - wind and weather conditions
  - the presence of unauthorized personnel
  - other possible unsafe conditions



### **WARNING**

**An operator should not use any aerial platform that:**

- does not appear to be working properly.
- has been damaged or appears to have worn or missing parts.
- has alterations or modifications not approved by the manufacturer.
- has safety devices which have been altered or disabled.

**Failure to avoid these hazards could result in death or serious injury.**



## 2.10-1 To Activate Base Control Console

**WARNING**

Ensure that you maintain three points of contact when using the ladder to mount/dismount platform.

1. Use the ladder of aerial platform to access platform.
2. Close the gate.
3. On platform control console, pull out "⊙" emergency stop button.
4. Select low/high throttle switch to "⊕" low throttle position.
5. Use the ladder to dismount from platform.
6. Turn emergency main power disconnect switch to "I" on position.
7. On base control console, pull out "⊙" emergency stop button.
8. For dual fuel engines, select fuel supply by moving fuel switch to either "⊕" gasoline or "⊖" liquid propane gas position.
9. Insert key into platform/engine/base key switch and select "⊕" base position.
10. For cold dual fuel engines, depress and hold "⊖" choke pushbutton. For cold diesel engines, depress and hold "⊕" glow plug pushbutton for 15 to 20 seconds.

**CAUTION**

Do not start the engine in the high throttle position.

11. Depress and hold "⊕" engine start pushbutton until engine starts, then release. Do not overcrank starter. Release "⊖" choke pushbutton after engine starts (dual fuel).

**NOTE**

Choke is only active while button is depressed. Occasional use of choke button may be necessary during the first few seconds of engine operation.

## 2.10-2 To Raise or Lower Platform Using Base Control Console

**WARNING**

Be aware of overhead obstructions or other possible hazards around the aerial platform when lifting.





**WARNING**

Do not lower the platform unless the area below is clear of personnel and obstructions.

1. Activate base control console (refer to [Section 2.10-1](#)).
2. On base control console, select and hold "⊕" base position on platform/engine/base key switch. Select and hold platform raise/lower switch to either "⊕" raise or "⊖" lower position. Release switch to stop.







**2.10-3 To Activate Platform Control Console**

1. Turn emergency main power disconnect switch to “I” on position.
2. On the base control console, pull out the “” emergency stop button.
3. For dual fuel engines, select fuel supply by moving fuel switch to either “” gasoline or “” liquid propane gas position.
4. Insert key into platform/engine/base key switch and turn it to “” enable platform controls.



**WARNING**

**Ensure that you maintain three points of contact when using the ladder to mount/dismount platform.**

5. Use the ladder of aerial platform to access platform.
6. Close the gate.
7. On platform control console, pull out “” emergency stop button.
8. Turn the low/high throttle switch to “” low throttle position.
9. For cold dual fuel engines, depress and hold “” choke pushbutton. For cold diesel engines, depress and hold “” glow plug pushbutton for 15 to 20 seconds.

**CAUTION**

**Do not start the engine in the high throttle position.**





10. Depress and hold “” engine start pushbutton until engine starts, then release. Do not overcrank starter. Release “” choke pushbutton after engine starts (dual fuel).

**2.10-4 To Raise or Lower Platform Using Platform Control Console****WARNING**

**Be aware of overhead obstructions or other possible hazards around the aerial platform when lifting.**

**WARNING**

**Do not lower the platform unless the area below is clear of personnel and obstructions.**

1. Activate platform control console (refer to [Section 2.10-3](#)).
2. On platform control console, select lift/torque/drive switch to “” lift position.
3. Activate and hold “” enable trigger switch.
4. Move controller handle forward “” to raise or backward “” to lower the platform, until desired height is reached.

**NOTE**

Lowering is not proportional.

5. Return controller to neutral center position to stop. Release enable trigger switch.

**WARNING**

**To protect against unintended movement of the aerial platform, push in the emergency stop button after you have arrived at your desired location or elevation.**

**NOTE**





If the tilt alarm sounds and the platform does not, or only partially raises, immediately lower the platform completely and ensure that the aerial platform is on a firm level surface.

**2.10-5 To Drive Forward or Backward****WARNING**

Be aware of blind spots when operating the aerial platform.

**WARNING**



Ensure that there are no personnel or obstructions in the path of travel, including blind spots.

1. Activate platform control console (refer to [Section 2.10-3](#)).
2. On platform control console, select lift/torque/drive switch to “” drive position.
3. Activate and hold “” enable trigger switch.
4. Move controller handle “” forward or “” backward to desired speed and direction of platform travel.
5. Return controller to neutral center position to stop. Release “” enable trigger switch.

**WARNING**

To protect against unintended movement of the aerial platform, push in the emergency stop button after you have arrived at your desired location or elevation.

**2.10-6 To Steer**

1. Activate platform control console (refer to [Section 2.10-3](#)).
2. On the platform control console, turn lift/torque/drive switch to “” drive position.
3. Activate and hold “” enable trigger switch.
4. Press “” rocker on top of controller handle in either direction to steer.

**NOTE**

Steering is not proportional. Driving and steering may be active at the same time.

### 2.10-7 To Select Drive Torque

1. **High Torque:** Select high torque when climbing grades, traveling on rough terrain or when loading or unloading aerial platform. To activate high torque, select lift/torque/drive switch to “” high torque (low speed) position.



#### **WARNING**

**Aerial platform must be in fully retracted position when operated on any grade. Driving while elevated on any grade may result in death or serious injury.**

2. **Low Torque:** Select low torque when traveling on flat surface. To activate low torque, select lift/torque/drive switch to “” low torque (high speed) position.



#### **WARNING**

**To protect against unintended movement of the aerial platform, push in the emergency stop button after you have arrived at your desired location or elevation.**

### 2.10-8 To Extend or Retract Manual Extension Platform

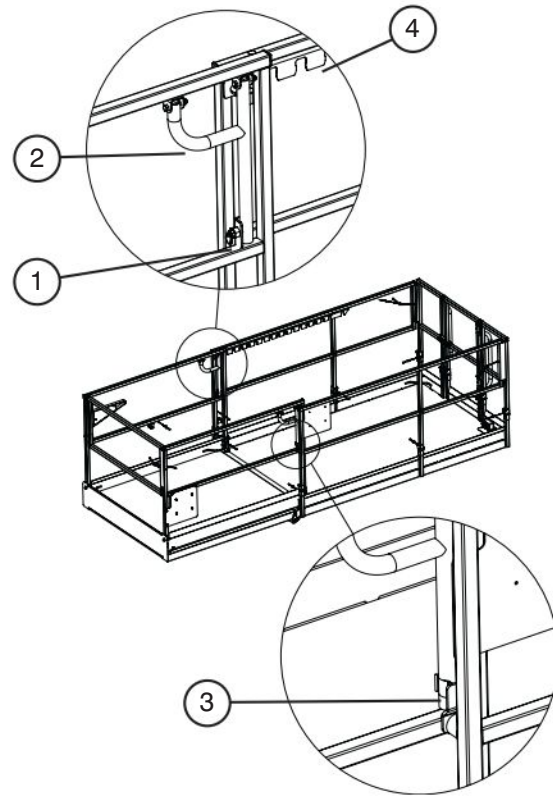

Figure 2-15. Manual Extension Platform

1. To extend/retract manual extension platform, pull out the pull pin (item 1), lift push bars (item 2) up from the gripper clip (item 3) then push/pull the push bar handle until desired extension/retraction is reached.
2. Ensure push bar rests in one of the slots in the extension interval (item 4). Fasten push bar down into the gripper clip and ensure pull pin is locked in place.



**2.10-9 Hydraulic Outriggers (If Equipped)**

These devices are mounted to four corners of the base. When properly positioned, they increase the stability of the aerial platform.





**2.10-9a Before Operation**

1. Move around aerial platform to check overhead clearances and ground obstructions.
2. To lower the platform completely, refer to [Section 2.10-4](#). Outrigger controls are not functional when platform is raised.
3. Check that the supporting surface under the tires and outrigger pads is firm and capable of supporting aerial platform and rated load. Do not place outrigger pad on a street drain, manhole cover or other unsupported surface.

**2.10-9b To Extend Outriggers**

4. On outrigger/generator control console, select and hold “” enable switch to provide power to outrigger circuit.
5. **Auto Extension:** Select auto-level switch to “” extend position until leveling indicator light stops flashing and remains in a solid state. Aerial platform should be completely supported by the outriggers and level at this point.

**Manual Extension:** Select corresponding outrigger extend/retract switch to “” extend position until platform is fully supported by outriggers and is level. The indicator light flashes while platform is being leveled and remains solid once platform is level. The indicator light has the following states:

-  **Off:** The outriggers are fully retracted.
-  **Flashing Rapidly:** The outriggers are extending but the platform is not level.
-  **Flashing:** The outriggers are extended but the platform is not yet level.
-  **Solid:** The outriggers are extended and the platform is level.

6. Ensure each outrigger pad is in firm contact over its entire surface area, with a suitable supporting surface! Make adjustments if necessary using manual outrigger controls.
7. Operate all non drive functions as described in their respective sections.

**NOTE**

Each outrigger pad must be in firm contact with the ground for most aerial platform functions to work.

**NOTE**



Drive functions are disabled if the outriggers are in any position other than fully retracted.



**WARNING**

**If alarm sounds during operation, the aerial platform is not level or an outrigger does not have firm ground contact. Lower the platform immediately! Make the necessary adjustments to level the aerial platform.**

**2.10-9c To Retract Outriggers**



8. On outrigger/generator control console, select and hold “” enable switch to provide power to outrigger circuit.
9. **Auto Retraction:** Select auto-level switch to “” retract position until outriggers are fully retracted.

**Manual Retraction:** Select corresponding pairs of outrigger extend/retract switch to “” retract position until outriggers are fully retracted.

**NOTE**

Limit switches are used to protect outriggers from being damaged. If drive functions are not available, visually check to see that all outriggers are fully retracted.

**2.10-10 Generator (If Equipped)****To start generator:**

1. On platform control console, select lift/torque/drive switch to “ lift position.
2. On outrigger/generator control console, select generator switch to “ energized position. The engine will automatically switch to low throttle and the generator will start.

**To restore normal operation:**

3. Flip generator switch to “” off position. The generator will turn off.

**NOTE**

Activating any lift or outrigger functions, changing key switch settings, activating emergency stop or an engine stall will turn off the generator. The platform may be lowered during generator operation.

**2.10-11 Electrical Inverter (If Equipped)**

The inverter is operational with alternating current available at all times when the aerial platform is on. The emergency stop button will turn the inverter off.

**To check status of inverter:**



1. Inverter state is indicated by the LEDs on the face of the inverter. A glowing green LED indicates normal operation. If a fault occurs, the status LEDs will indicate the area responsible. Refer to [Section 2.6-2](#).

**2.10-12 Shutdown Procedure**

1. Completely lower the platform.
2. On the platform control console, push in “” emergency stop button.

**WARNING**

**Ensure that you maintain three points of contact when using the ladder to mount/dismount platform.**

3. Use the ladder to dismount from platform..
4. Turn platform/engine/base key switch to “” engine position and remove key.
5. Turn emergency main power disconnect switch to “” off position.

## 2.11 Refueling Procedure

This section provides the operator with the procedure on how to refuel the engine with regular fuel and install the propane cylinder.

### **IMPORTANT**

**Before using the aerial platform ensure there is enough fuel to finish the job.**



### **WARNING**

**Follow all local and national regulations for propane handling.**

- Use extreme caution while refueling aerial platforms.
- Ensure engine and all systems are turned off before refueling.
- Refuel aerial platform only in a well ventilated area away from open flame and other sources of ignition, authorized by your employer and supervisor.
- Liquid propane gas fuel is a gas that is heavier than air. It settles in low spots. Any flame or spark could cause a fire that could cause serious injury.
- When changing liquid propane gas cylinder, check all connections for damage or missing parts. Never try to start an aerial platform if you smell gas.
- For gasoline engine models, use only unleaded gasoline with an octane rating 87 or higher.



### **WARNING**

**Do not smoke in an area where aerial platforms are stored or refueled.**

## 2.11-1 Regular Fuel

1. Ensure engine and all systems are turned off and emergency stop buttons are depressed.
2. Open fuel compartment door and remove fuel cap.
3. Carefully pour fuel into tank ensuring that no spillage occurs.
4. Securely replace fuel cap.
5. Ensure there are no leaks in the fuel system.
6. Wipe up any spilled fuel.
7. Dispose of rags in an approved container.

## Protection of Environment from Chemical Dangers



### **WARNING**

Gasoline, diesel fuel, engine oil and hydraulic fluid are chemicals, which can contaminate the environment. If they are spilled during filling and reach the water, they can cause damage to the environment, e.g., death of fish. For such damage, the party responsible is liable! Therefore, gasoline, diesel fuel, engine oil or hydraulic fluid must not get into the sewage system, streams, rivers or other surface water. For that reason, immediately remove the dripped off or spilled gasoline, diesel fuel, engine oil or hydraulic fluid with appropriate means and dispose of these means according to the regulations.

**2.11-2 Propane****WARNING**

**Follow all local and federal regulations for propane handling.**

**To remove a propane cylinder:**

1. Ensure engine and all systems are turned off and emergency stop button is depressed.
2. Turn propane cylinder's main valve clockwise to shut off fuel supply to engine.
3. Start engine and allow it to stop naturally. Restart engine to ensure fuel lines are empty.
4. Disconnect hose from empty propane cylinder by detaching the coupling. Turn fitting counterclockwise.
5. Loosen two propane cylinder straps by pulling up on the metal clips. Disconnect straps from hooks.
6. Remove the propane cylinder.

**To install a propane cylinder:**

1. Ensure engine and all systems are turned off and emergency stop button is depressed.
2. Place propane cylinder on bracket or in compartment.
3. Ensure metal peg on bracket or compartment is inserted into propane cylinder rim.
4. Reconnect propane cylinder straps to hooks and fasten tightly.
5. Attach coupler to propane cylinder and turn clockwise to tighten fitting.
6. Apply soap water or neutral detergent to pipe connection and cylinder.
7. Open valve 1/4 turn counterclockwise and check for any gas leaks.
8. Wipe off soap water or detergent after inspection is completed.
9. Open main valve fully if there are no leaks.

**NOTE**

The aerial platform is now ready for use by an authorized, qualified operator who has read and completely understands all of [Section 2](#) operations in this manual.



**2.12 Loading/Unloading**

Know all national, state or territorial/provincial and local rules which apply to your loading/unloading of aerial platforms.

Only qualified personnel shall operate machinery during loading/unloading.

Be sure vehicle capacity and loading equipment hoists, chains, straps, etc., are sufficient to withstand maximum aerial platform weight.

The transport vehicle must be parked on a level surface and must be secured to prevent rolling while aerial platform is being loaded/unloaded.

**2.12-1 Lifting**

When it is necessary to lift the Skyjack aerial platform the following conditions must be met:

- The platform must be fully lowered.
- The emergency main power disconnect switch must be in “○” off position.
- The hydraulic/fuel and engine compartments must be closed and securely latched.
- The extension platform must be retracted and secured.
- The platform control console must be secured to the railings or removed.
- The platform must be cleared of all personnel, tools and materials.
- The lifting/rigging may be attached to all twelve lifting points as illustrated in [Figure 2-16](#).

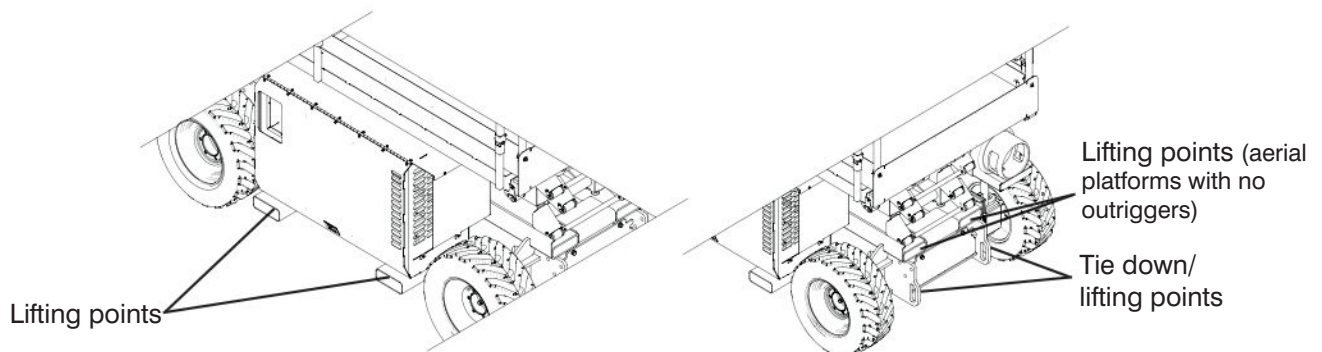

Figure 2-16. Tie Downs/Lifting Points

**NOTE**

The mass of the aerial platform is as per [Table 2-1](#). The center of gravity is approximately located in the middle of the aerial platform, front to back and side to side, as illustrated in [Figure 2-17](#). Vertically, the center of gravity is approximately just above the base chassis.

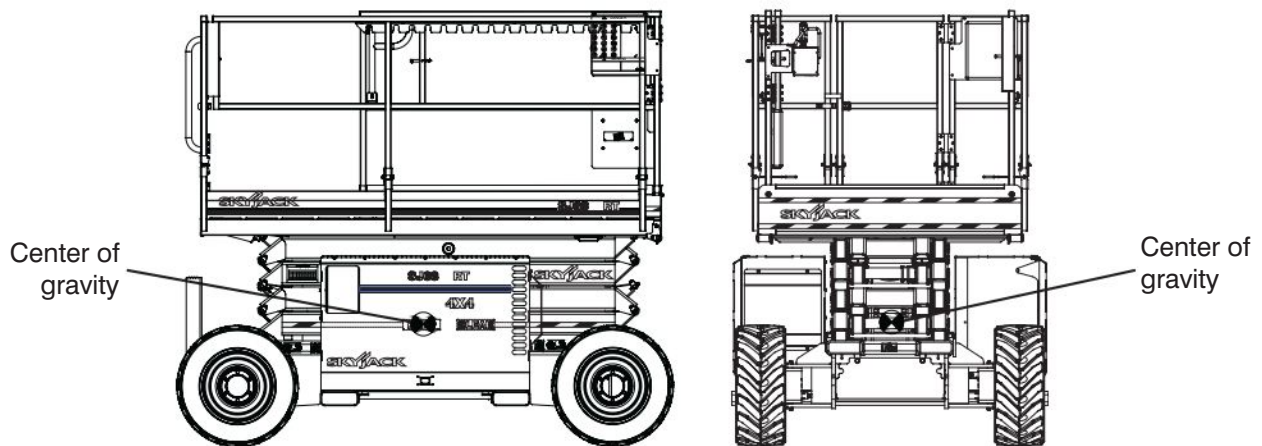

Figure 2-17. Center of Gravity

**NOTE**

The aerial platform can be lifted with a forklift from the sides but Skyjack does not recommend this use. Lift with forks in designated pockets as illustrated in [Figure 2-18](#).

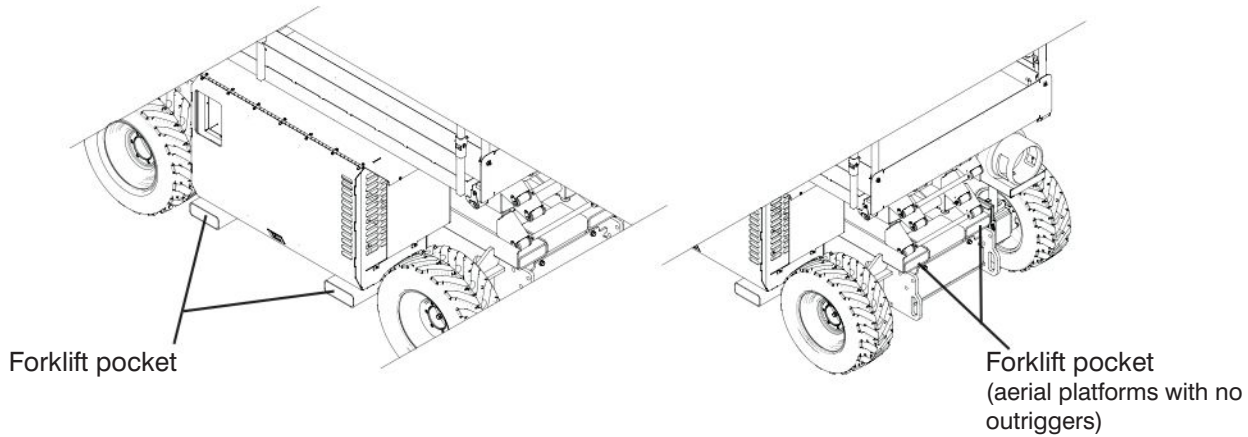

Figure 2-18. Forklift Pockets

**2.12-2 Driving**

When driving the aerial platform:

- Ramp or dock capacity should be sufficient to withstand maximum aerial platform weight.
- Ramp should be equipped with side guards to prevent inadvertent fall from the ramp.
- Incline should not exceed aerial platform gradeability (refer to [Table 2-1](#)).
- Aerial platform brakes should be checked for proper operation.
- Aerial platform speed should be on high torque setting.

**WARNING**

**When transporting, the aerial platform must be secured to the truck or trailer deck. Tie downs are available as illustrated in [Figure 2-16](#).**

### 2.13 Guardrail Folding Procedure

When folded down, the folding guardrail system reduces the height of the retracted aerial platform for transporting only.



#### WARNING

**Any lowered guardrail will create a fall hazard. Remain away from the sides of the platform while raising or lowering the guardrails to avoid falling.**

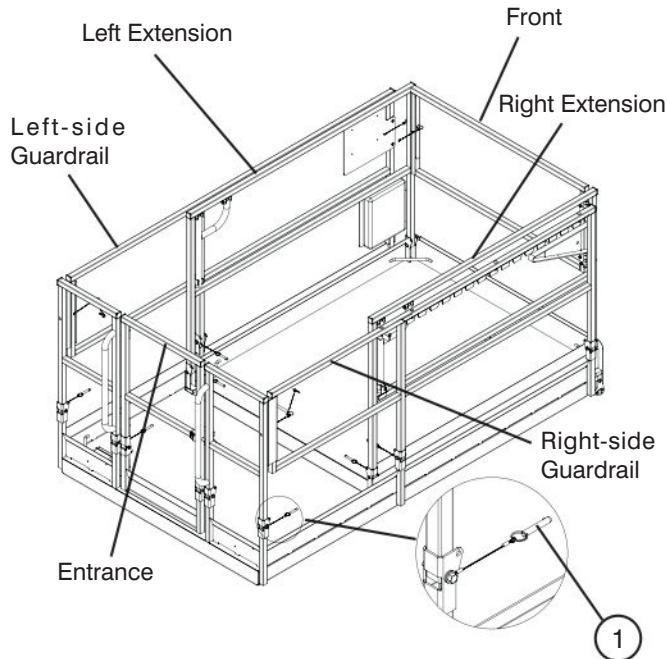

Figure 2-19a. Folding Guardrail System

1. **Guardrail Locking Pin with Lanyard** - This pin is used to lock the guardrail in place.



#### WARNING

**Before operating this aerial platform check the guardrail system for loose or missing locking pins. The guardrail system must be upright and all pins must be locked in place. Death or serious injury could result if the guardrail system is not upright or properly locked.**



#### WARNING

**The scissor assembly must be fully lowered before raising or lowering the guardrails.**

To fold the guardrail system down:

1. Ensure aerial platform is on level ground.
2. Remove the platform control console and outrigger controls (if equipped) and lay it down on the platform.
3. Turn emergency main power disconnect switch to "O" off position.



#### WARNING

**Ensure that you maintain three points of contact when using the ladder to mount/dismount platform.**

4. Use the ladder of aerial platform to access platform.
5. Close the gate.
6. Retract the extension platform fully. Refer to [Section 2.10-8](#).



#### WARNING

**Any lowered guardrail will create a fall hazard. Remain away from the sides of the platform while raising or lowering the guardrails to avoid falling.**

7. Fold down guardrails in the following order: front, right extension, right-side, left extension, left-side and entrance (refer to [Figure 2-19a](#)).
8. Remove the locking pin that secured the front guardrail to the left extension guardrail then swing it towards the right extension.
9. Remove the locking pin on the right extension guardrail and fold it down with the front guardrail.

10. Remove the locking pins on the right-side guardrail and fold it down.
11. Remove the locking pin on the left extension and fold it down.
12. Remove all the locking pins on the left-side guardrail and fold it down.
13. With the gate closed, remove all the locking pins on the entrance guardrail and fold the guardrail down.

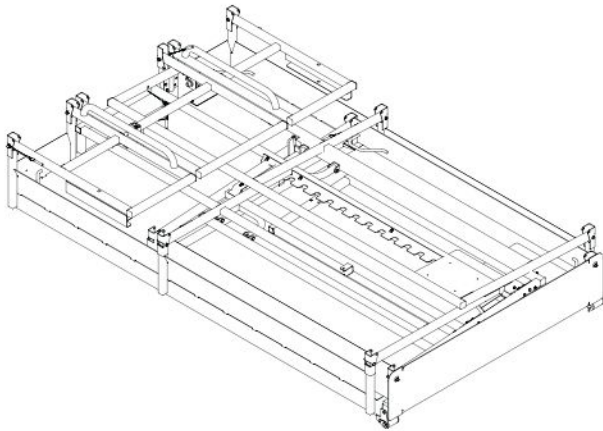

Figure 2-19b. All Guardrails Folded Down

**To raise the guardrail system up:**



**WARNING**

**The scissor assembly must be fully lowered before raising or lowering the guardrails.**

1. Ensure that the aerial platform is on level ground.
2. Turn emergency main power disconnect switch to "○" off position.



**WARNING**

**Ensure that you maintain three points of contact when using the ladder to mount/dismount platform.**

3. Use the ladder of aerial platform to access platform.



**WARNING**

**Any lowered guardrail will create a fall hazard. Remain away from the sides of the platform while raising or lowering the guardrails to avoid falling.**



**WARNING**

**Ensure that the detent ball of each locking pin is all the way through and each cotter pin fully inserted into the pin hole.**

4. Raising the guardrails up is done in the following order: entrance, left side, left extension, right side, right extension and front.
5. Swing up the entrance guardrail then lock it in place by inserting all locking pins.
6. Swing up the left-side guardrail and lock it in place by inserting all locking pins.
7. Swing up the left extension guardrail and lock it in place by inserting the locking pin.
8. Swing up the right-side guardrail and lock it in place by inserting all locking pins.
9. Swing up the right extension guardrail and the front guardrail and lock them in place by inserting the locking pin on the right extension.
10. Swing the front guardrail forward and lock it in place by inserting the locking pin.
11. Mount the platform control console and outrigger controls (if equipped) at the front right of the platform. Lock them in place.



**WARNING**

**Before operating this aerial platform check the guardrail system for loose or missing locking pins. The guardrail system must be upright and all pins must be locked in place. Death or serious injury could result if the guardrail system is not upright or properly locked.**

## 2.14 Moving the Aerial Platform Through a Doorway



### WARNING

This procedure is suitable for level ground only.

1. Confirm that the height/width of the doorway is sufficient to allow the aerial platform to pass through.

### NOTE

If it is necessary to fold the guardrails, refer to [Section 2.13](#) for guardrail folding procedure.



2. Perform a thorough jobsite inspection prior to operating the aerial platform to identify potential hazards in your work area.
3. Cordon-off the pathway which you intend to travel.
4. Position the aerial platform to allow all future motion, including through the doorway, to be in a forward direction.
5. Turn emergency main power disconnect switch to “○” off position.
6. Use the ladder of aerial platform to access platform.



### WARNING

Ensure that you maintain three points of contact when using the ladder to mount/dismount platform.

7. Close the gate. On platform control console, push in “●” emergency stop button.
8. Disconnect and remove platform control console from the platform.
9. Fold the guardrails if necessary. (Refer to [Section 2.13](#) for guardrail folding procedure.)
10. Use the ladder to dismount from platform.
11. Connect platform control console to the connection inside the engine cabinet.

12. Ensure there are no personnel in the intended path of travel.
13. Notify those around the pathway that you will be moving the aerial platform.
14. Use a spotter to guide movement. Ensure the spotter remains at a safe distance.
15. Ensure that the platform control console is properly oriented in the direction the aerial platform is facing.
16. Turn emergency main power disconnect switch to “|” on position.
17. On base control console, pull out “●” emergency stop button.
18. Insert key into platform/engine/base key switch and turn it to “” platform position.
19. On platform control console, pull out “●” emergency stop button.
20. Turn low/high throttle switch to “” low throttle position.



### CAUTION

Do not start the engine in the high throttle position.

21. Start engine.



### DANGER

Do not drive the aerial platform toward yourself.

22. On platform control console, select lift/torque/drive switch to “” low speed drive position.
23. Using as low a speed as practical and the operator positioned behind the aerial platform, drive forward through doorway.
24. Once safely through doorway, push in “●” emergency stop button and turn emergency main power disconnect switch to “○” off position.

25. Disconnect platform control console and return it to the platform.

**WARNING**

**Ensure that you maintain three points of contact when using the ladder to mount/dismount platform.**

26. Return guardrails to upright position if folded. (Refer to [Section 2.13](#) for guardrail folding procedure.)

**WARNING**

**Before operating this aerial platform check the guardrail system for loose or missing locking pins. The guardrail system must be upright and all pins must be locked in place.**

**Death or serious injury could result if the guardrail system is not upright or properly locked.**

27. Once platform control console is securely reconnected and guardrails up, normal operation may continue.



## 2.15 Winching and Towing Procedure

This section provides the operator with procedure about winching and towing and how to release the brakes.



### WARNING

Ensure platform is fully lowered before winching or towing. Sudden motion could cause the aerial platform to become unstable. Death or serious injury could result.



### WARNING

In emergency situations where aerial platform functions are not available and lowering is impeded by an obstacle, utmost care must be taken to move aerial platform far enough to clear obstacle. In such cases, operation must be extremely smooth with no sudden movements and must not exceed a speed of 2"/sec (50 mm/sec).



### WARNING

When pushing, winching or towing, do not exceed 2 mph (3.2 km/h).



### WARNING

Do not push, winch or tow aerial platform onto a slope, or brake the towing vehicle rapidly. Do not pull aerial platform down an incline towards a winch.

## 2.15-1 To Release Free-wheeling Valve

1. Ensure aerial platform is on level ground. Chock or block the wheels to prevent aerial platform from rolling.



Figure 2-20. Free-wheeling Valve

2. **Free-wheeling Valve** - Turning the valve knob counterclockwise (item 1) to a fully opened position allows fluid to flow through the wheel motors, thus providing "free-wheeling".



### WARNING

The free-wheeling valve must be closed tightly (clockwise) for normal operation.



## 2.15-2 To Release Brakes Manually

**WARNING**

**Do not manually disengage brakes if the aerial platform is on a slope.**



Figure 2-21. Disc Brakes System

**NOTE**

Brakes must be manually disengaged for pushing, winching or towing.

1. Ensure aerial platform is on level ground. Chock or block wheels to prevent aerial platform from rolling.
  2. Turn emergency main power disconnect switch to "○" off position.
  3. Locate brake auto reset valve plunger (item 1) and brake hand pump (item 2) at the main manifold in the hydraulic/fuel compartment.
  4. Push in brake auto reset valve plunger.
  5. Grasp brake hand pump and rapidly depress until firm resistance is felt. The brakes are now released.
  6. Remove wheel chocks or blocks, then push, winch or tow aerial platform to desired location.
8. Chock or block wheels to prevent aerial platform from rolling.
  9. Reengage brakes by pulling out brake auto reset valve plunger.

**WARNING**

**Brakes must be reengaged immediately after reaching the desired location.**

7. Position aerial platform on a firm and level surface.

## 2.16 Emergency Lowering Procedure

This section guides the operator on how to use emergency lowering system. This system allows platform lowering in the event of an emergency or an engine malfunction.



### WARNING

**Keep clear of scissors mechanism when using emergency lowering valve.**

1. Remove any obstructions from a descending platform.
2. Extension platform(s) may need to be retracted or aerial platform may need to be moved to clear obstruction. Refer to [Section 2.15](#) for winching and towing procedures.

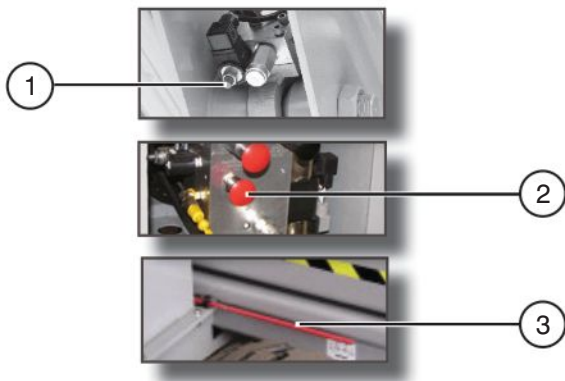

Figure 2-22. Emergency Lowering System

3. Locate holding valve override knob (item 1) at base of each lift cylinder. Depress and turn counterclockwise (1/4 turn). If necessary, use emergency lowering access rod (item 3) located on aerial platform base.
4. On the hydraulic/fuel compartment, pull out and hold emergency lowering pull valve (item 2) to lower platform.
5. To restore normal operation, depress and turn the holding valve override knobs clockwise.

## 2.17 Maintenance Support Procedure

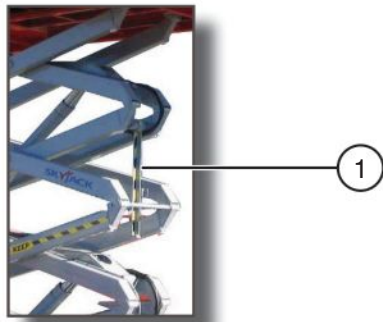

Figure 2-23. Maintenance Support

1. **Maintenance Support** - The maintenance support is a safety mechanism designed to support the scissor assembly. When properly positioned it can support the scissor assembly and empty platform. The maintenance support must be used when inspection and/or maintenance is to be performed within the lifting mechanism.



### **WARNING**

**The maintenance support must be used when inspection and/or maintenance or repairs are to be performed within the lifting mechanism. Failure to use this safety mechanism could result in death or serious injury.**

### To Deploy the Maintenance Support

1. Remove all material from platform.
2. Raise platform until there is adequate clearance to swing down maintenance support.
3. Swing maintenance support down from storage bracket into a vertical position.
4. Remove hands and arms from scissors area.
5. Lower platform until bottom end of maintenance support contacts the labeled cross bar and scissors are supported by maintenance support.
6. Turn emergency main power disconnect switch to "○" off position.

### To Store the Maintenance Support

1. Turn emergency main power disconnect switch to "I" on position.
2. Raise platform until there is adequate clearance to swing up the maintenance support.
3. Swing bar up into storage bracket.
4. Lower the platform.



### **WARNING**

**Do not reach through the scissor assembly when the platform is raised without the maintenance support properly positioned. Failure to avoid this hazard could result in death or serious injury.**

**Table 2.1 Standard and Optional Features**

MODEL	Compact RT's	
	6826	6832
<b>STANDARD EQUIPMENT</b>		
Platform controls	*	*
Base controls	*	*
Four-wheel drive	*	*
23.1 kW (31 hp) Kubota DF972 dual fuel - gasoline/propane engine	*	*
Easy operation 60" roll out extension	*	*
Swing out engine tray	*	*
Multiple wet disc – Spring applied hydraulic release brakes	*	*
Manual brake release	*	*
110V AC outlet on platform	*	*
Tilt alarm with drive/lift cutout	*	*
Lanyard attachment points	*	*
Hinged railing system	*	*
Operator horn	*	*
Spring loaded full height gate at rear	*	*
Forklift pockets, tie down/lifting lugs	*	*
Foam filled low profile grip lug tires	*	*
Hourmeter	*	*
Color coded and numbered wiring system	*	*
Hydraulic oil level indicators	*	*
<b>OPTIONAL EQUIPMENT</b>		
Flashing light	*	*
18.5 kW (24.8 hp) Kubota D902 diesel water-cooled engine	*	*
Diesel scrubber	*	*
All motion audible alarm	*	*
Shop air line to platform	*	*
800 Watt AC inverter	*	*
Work lights	*	*
Independent leveling hydraulic outriggers	*	*
Extra propane tank	*	*

60436AE-ANSI

Table 2.2 Specifications and Features

Model		Compact RT's			
		6826		6832	
Weight*	No Outriggers	6400 lb.	2903 kg	7660 lb.	3475 kg
	With Outriggers	7500 lb.	3402 kg	8060 lb.	3656 kg
Width		68"	1.73 m	68"	1.73 m
Length	No Outriggers	106.6"	2.71 m	106.6"	2.71 m
	With Outriggers	131.4"	3.34 m	131.4"	3.34 m
Platform Size		56" x 99"	1.4 m x 2.5 m	56" x 99"	1.4 m x 2.5 m
Height	Working	32 ft.	9.8 m	38 ft.	11.7 m
	Platform Elevated	26 ft.	8 m	32 ft.	9.8 m
	Platform Lowered	7.8 ft.	2.37 m	8.25 ft.	2.52 m
	Drive	26 ft.	7.95 m	32 ft.	9.8 m
Speed	Normal Drive	4 mph	6.3 km/h	4 mph	6.3 km/h
	Elevated Drive	0.39 mph	0.63 km/h	0.39 mph	0.63 km/h
	Lift (Rated Load)	36 sec		39 sec	
	Lower (Rated Load)	36 sec		36 sec	
Engine (RPM)	Kubota Diesel	3500 (High Throttle) / 2050 (Low Throttle)			
	Kubota Dual Fuel	3500 (High Throttle) / 2050 (Low Throttle)			
Tires	Foam-filled	OTR Outrigger - 26 x 12			
	Air-filled	N/A			
Sound Pressure		96 dB(A)			
Gradeability (Torque Equivalent To)		50%		40%	

60440AG-ANSI

\* Weights are approximate; refer to serial nameplate for specific weight.

**Table 2-3. Owner's Annual Inspection Record**

<b>Model Number:</b> _____		<b>Serial Number:</b> _____							
<b>Recording Date</b>									
<b>Recording Year #</b>	1	2	3	4	5	6	7	8	9
<b>Owner's Name</b>									
<b>Inspected By</b>									

60141AB

As described earlier in this section, this decal is located on the scissor assembly. It must be completed after an annual inspection has been completed. Do not use the aerial platform if an inspection has not been recorded in the last 13 months.



Table 2-4. Maximum Platform Capacities (Evenly Distributed)

MODEL		Total Machine Weight			Extension		
		Capacity		Number of Occupants	Capacity		Number of Occupants
6826	One Extension Platform	1250 lb.	567 kg	4	300 lb.	136 kg	1
6832	One Extension Platform	1000 lb.	453.6 kg	4	300 lb.	136 kg	1

60441AC-ANSI

**NOTE:**

Occupants and materials are not to exceed rated load.  
Refer to capacity label for additional information and for models equipped with options.

**Table 2-5. Floor Loading Pressure**

MODEL		Total Aerial Platform Weight		Total Aerial Platform Load					
				Wheel		LCP**		OUP**	
		lb.	kg	lb.	kg	psi	kPa	psf	kg/m <sup>2</sup>
6826	min*	6400	2903	2560	1161	157.4	1085	206	1007
	max*	8730	3960	3492	1584	175.41	1209	281	1373
6832	min*	7661	3475	3064	1390	165.59	1142	247	1205
	max*	9235	4189	3605	1635	181.36	1250	297	1452

60442AE-ANSI

- \* **min** - Total aerial platform weight with no options  
**max** - aerial platform weight + all options + full capacity
- \*\* **LCP – Locally Concentrated Pressure** is a measure of how hard the aerial platform presses on the areas in direct contact with the floor. The floor covering (tile, carpet, etc.) must be able to withstand more than the indicated values above.  
**OUP – Overall Uniform Pressure** is a measure of the average load the aerial platform imparts on the whole surface directly underneath it. The structure of the operating surface (beams, etc.) must be able to withstand more than the indicated values above.

**NOTE:**

The **LCP** or **OUP** that an individual surface can withstand varies from structure to structure and is generally determined by the engineer or architect for that particular structure.

**Table 2-5. Floor Loading Pressure**

**Locally Concentrated Pressure (LCP):**

$$\text{Foot Print Area} = \text{Length} \times \text{Width} \\ = \pi r^2$$

$$\text{LCP} = \frac{\text{Weight of Aerial Platform} + \text{Capacity}}{\text{Foot Print Area} \times 4 \text{ (Tires)}}$$

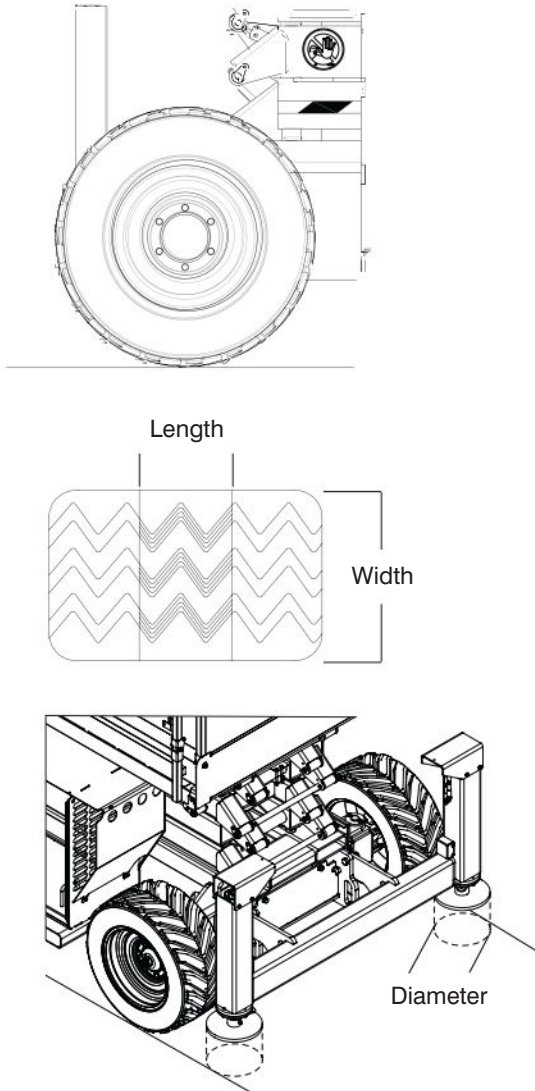

**Overall Uniform Pressure (OUP):**

$$\text{Base Area} = \text{Length} \times \text{Width}$$

$$\text{OUP} = \frac{\text{Weight of Aerial Platform} + \text{Capacity}}{\text{Base Area}}$$

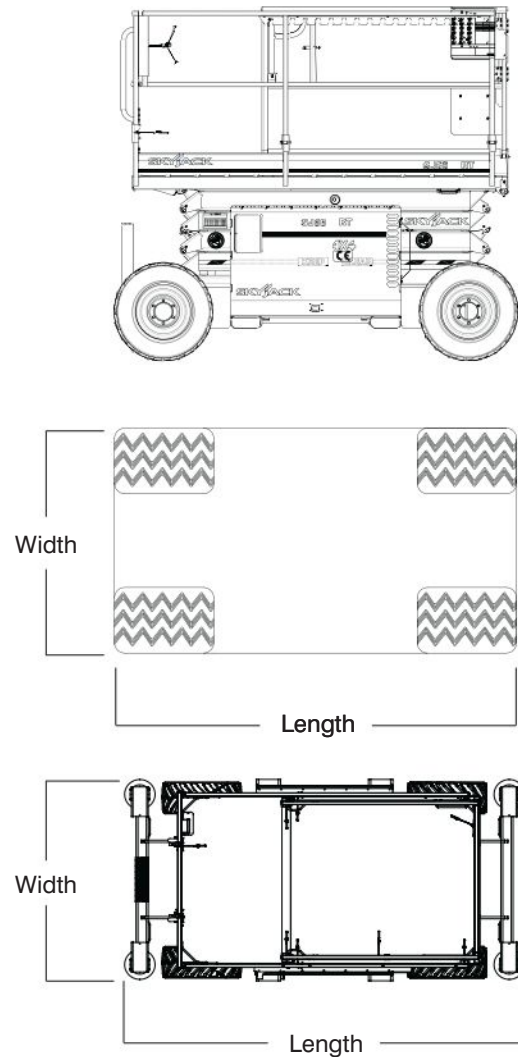

**! WARNING**

**Intermixing tires of different types or using tires of types other than those originally supplied with this equipment can adversely affect stability. Therefore, replace tires only with the exact original Skyjack-approved type. Failure to operate with matched approved tires in good condition may result in death or serious injury.**

**General Maintenance**

Before attempting any repair work, disconnect battery by turning emergency main power disconnect switch to “○” off position. Preventive maintenance is the easiest and least expensive type of maintenance.

**Table 2.6 Maintenance and Inspection Schedule**

Frequency	Daily	3 months or 150 hours	Yearly	Frequency	Daily	3 months or 150 hours	Yearly
<b>Visual and Daily Maintenance Inspections</b>				<b>Base</b>			
Labels	A			Base Weldment	A		
Electrical	A			Wheel/Tire Assembly	A		
Limit Switches	A			Steer Cylinder Assembly	A		
Hydraulic	A			Splitter Manifold	A		
<b>Engine Compartment</b>				Tie Rod	A		
Emergency Main Power Disconnect Switch	A			Emergency Lowering Access Rod	A		
Base Control Switches	A			Ladder	A		
Tilt Sensor	A			Outriggers	A		
Battery	A			<b>Function Tests</b>			
Hydraulic Pump	A			<b>Test Emergency Main Power Disconnect Switch</b>	A		
Radiator	A			<b>Base Control Console</b>			
Muffler and Exhaust	A			Test Platform/Engine/Base Key Switch	A		
Engine Pivot Tray	A			Test Emergency Stop	A		
Engine Oil Level	A			Test Platform Raise/Lower Switch	A		
Fuel Shut-off Valve	A			Test Emergency Lowering	A		
Engine Air Filter	A			Test Free-wheeling	A		
Fuel Leaks	A			<b>Platform Control Console</b>			
<b>Hydraulic/Fuel Compartment</b>				Test Emergency Stop	A		
Hydraulic Tank	A			Test Enable Trigger Switch	A		
Hydraulic Oil	A			Test Platform Raising/Lowering	A		
Hydraulic Return Filter	A			Test Steering	A		
Fuel Tank	A			Test Driving	A		
Fuel Leaks	A			Test Speed Limit	A		
Main Manifold	A			Test Brakes	A		
Gear Type Flow Divider	A			Test Horn	A		
<b>Platform Assembly</b>	A						
Lanyard Attachment Anchors	A						
AC Outlet on Platform	A						
Manuals	A						
Platform Control Console	A						
<b>Lifting Mechanism</b>							
Maintenance Support	A						
Scissor Assembly	A						
Scissor Bumpers	A						
Rollers	A						
Lift Cylinder(s)	A						

B\*†

B\*†

B\*†

60601AC-ANSI

**A** - Perform Visual and Daily Maintenance Inspections & Functions Test. Refer to Section 2.8 and Section 2.9 of this manual.

**B** - Perform Scheduled Maintenance Inspection. Refer to Service & Maintenance manual.

\* - Maintenance must be performed only by trained and competent personnel who are familiar with mechanical procedures.

† - Refer to Skyjack's website @ [www.skyjack.com](http://www.skyjack.com) for latest service bulletins prior to performing quarterly or yearly inspection



**WARNING**

**Use original or manufacturer-approved parts and components for aerial platform.**

Table 2.7 Operator's Checklist



Serial Number: \_\_\_\_\_  
 Model: \_\_\_\_\_  
 Hourmeter Reading: \_\_\_\_\_  
 Date: \_\_\_\_\_  
 Time: \_\_\_\_\_

Operator's Name (Printed): \_\_\_\_\_  
 Operator's Signature: \_\_\_\_\_

Each item shall be inspected using the appropriate section of the Skyjack operating manual. As each item is inspected, check the appropriate box.

- P** - PASS
- F** - FAIL
- R** - REPAIRED
- NA** - NOT APPLICABLE
- DAILY
- FREQUENTLY
- ANNUALLY
- BI-ANNUALLY







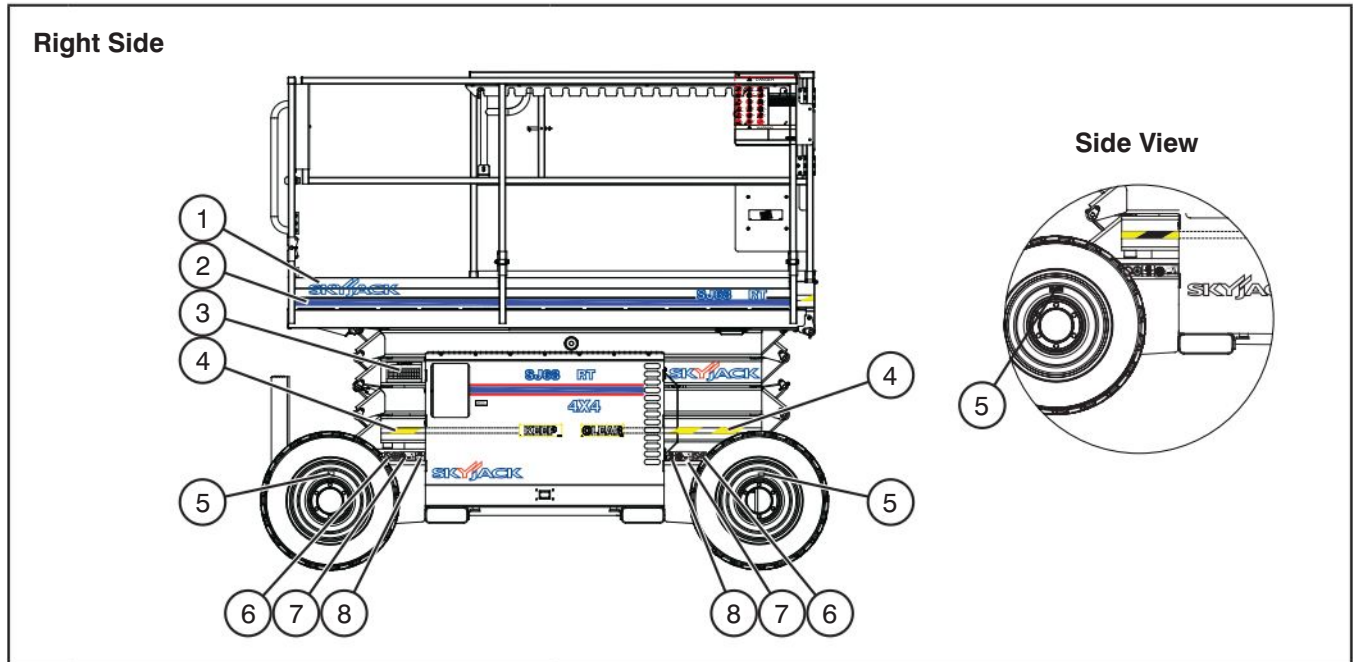

	N/A	P	F	R
<b>Visual and Daily Maintenance Inspections</b>				
<b>Labels</b>				
<b>Electrical</b>				
<b>Limit Switches</b>				
<b>Hydraulic</b>				
<b>Entrance Side</b>				
Emergency Main Power Disconnect Switch				
Base Control Switches				
Tilt Sensor				
Battery				
Hydraulic Pump				
Radiator				
Muffler and Exhaust				
Engine Pivot Tray				
Engine Oil Level				
Fuel Shut-off Valve				
Engine Air Filter				
Fuel Leaks				
<b>Hydraulic/Fuel Compartment</b>				
Hydraulic Tank				
Hydraulic Oil				
Hydraulic Return Filter				
Fuel Tank				
Fuel Leaks				
Main Manifold				
Gear Type Flow Divider				
<b>Platform Assembly</b>				
Lanyard Attachment Anchors				
AC Outlet on Platform				
Manuals				
Platform Control Console				
<b>Lifting Mechanism</b>				
Maintenance Support				
Scissor Assembly				
Scissor Bumpers				

	N/A	P	F	R
<b>Base</b>				
Base Weldment				
Wheel/Tire Assembly				
Steer Cylinder Assembly				
Splitter Manifold				
Tie Rod				
Emergency Lowering Access Rod				
Ladder				
Outriggers				
<b>Function Tests</b>				
<b>Test Emergency Main Power Disconnect Switch</b>				
<b>Base Control Console</b>				
Test Platform/Engine/Base Key Switch				
Test Emergency Stop				
Test Platform Raise/Lower Switch				
Test Emergency Lowering				
Test Free-wheeling				
<b>Platform Control Console</b>				
Test Emergency Stop				
Test Enable Trigger Switch				
Test Platform Raising/Lowering				
Test Steering				
Test Driving				
Test Speed Limit				
Test Brakes				
Test Horn				

60602AB-ANSI







**Note:**  
 Make a copy of this page or visit the Skyjack web site:  
[www.skyjack.com](http://www.skyjack.com) for a printable copy.

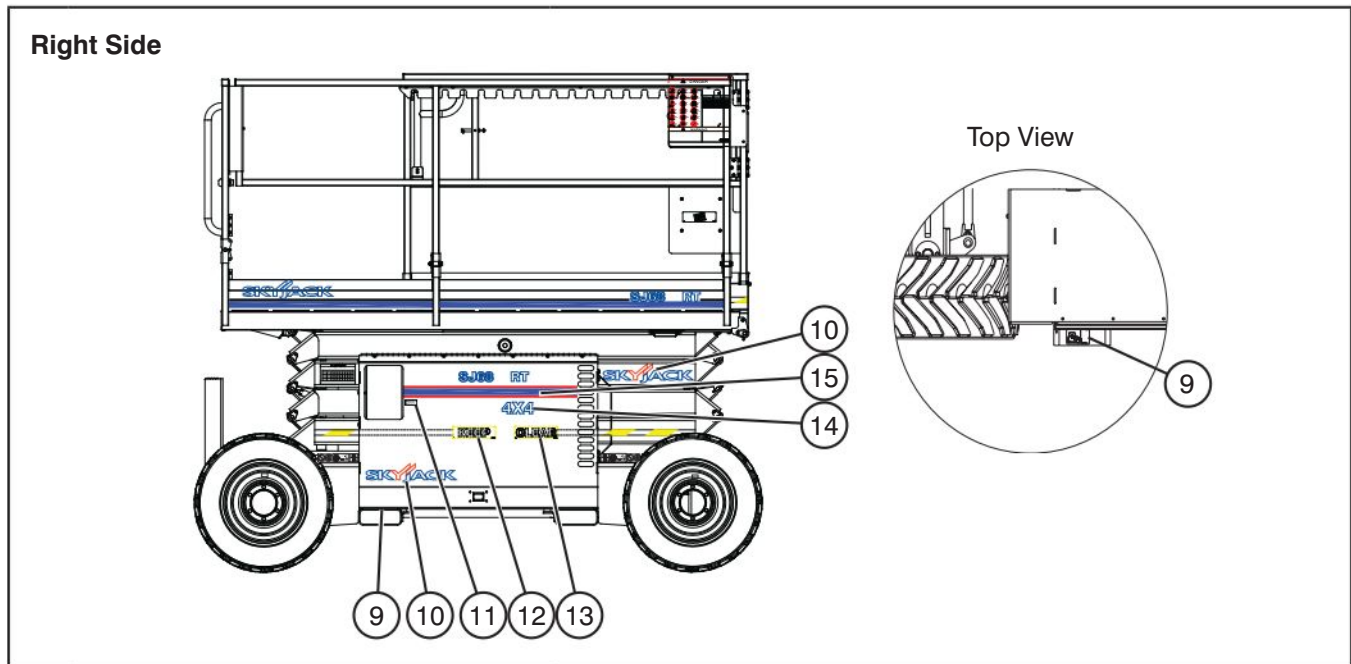



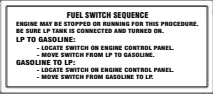

No.	Label Pictorial	Description
1		<b>Skyjack Logo</b> Small Skyjack logo - blue
2		<b>Tape Blue/White</b> Skyjack pinstripe
3		<b>Annual Inspection</b> Ensure that work platform has received annual inspection prior to operation.
4		<b>Caution Tape Stripe</b> Caution stripe
5		<b>Tire Sealant</b> Indicates that tire sealant is present inside the tires.
6		<b>Foam-filled Tire</b> Indicates foam-filled tire only.
7		<b>Wheel Load 1635 kg/3600 lb.</b> Indicates rated wheel load.
8		<b>Wheel Specifications</b> Refer to manual for wheel type, offset, pressure and torque.



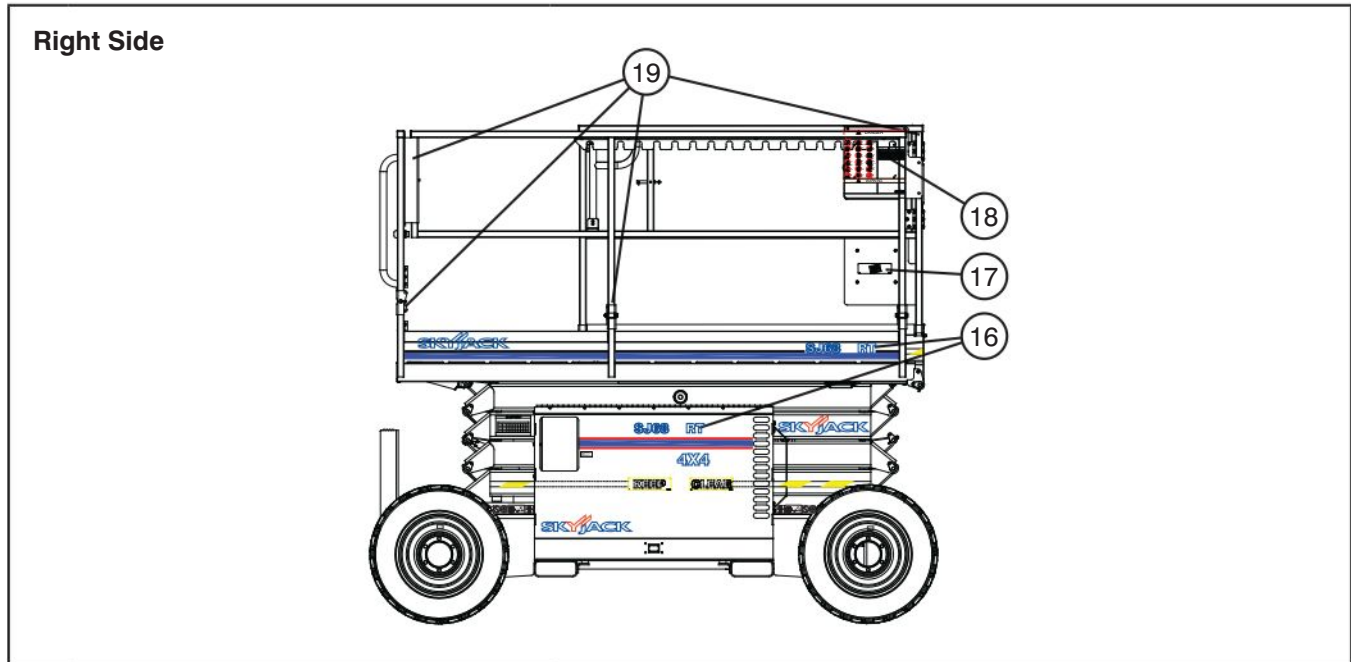

No.	Label Pictorial	Description
9		<p><b>Forklift Pocket</b></p> <p>Insert fork fully into pocket to lift aerial platform.</p>
10		<p><b>Skyjack Logo</b></p> <p>Small Skyjack logo - blue and red</p>
11		<p><b>Fuel Switch Sequence</b></p> <p>Follow procedure outlined to switch between L.P.Gas/Gasoline.</p>
12		<p><b>“Keep”</b></p> <p>Keep clear.</p>
13		<p><b>“Clear”</b></p> <p>Keep clear.</p>
14		<p><b>4x4</b></p> <p>Product identifier - 4 wheel drive</p>
15		<p><b>Tape - Red/Blue/Red</b></p> <p>Skyjack pinstripe</p>



No.	Label Pictorial	Description
16	<p style="text-align: center;"><b>SJ6826RT</b></p> <hr/> <p style="text-align: center;"><b>SJ6832RT</b></p>	<p><b>Model Number*</b></p> <p>Product Identifier                      *Model number will vary, may not be as shown.</p>
17		<p><b>Manual Storage Box</b></p> <p>Indicates location of operating manual.</p>
18		<p><b>Hazard Identification</b></p> <p>Read and understand the outlined risks associated with this work platform prior to operation.</p>
19		<p><b>Railing Pins (Vertical)</b></p> <p>WARNING! Falling Hazard. Ensure hinged railing is pinned.</p>

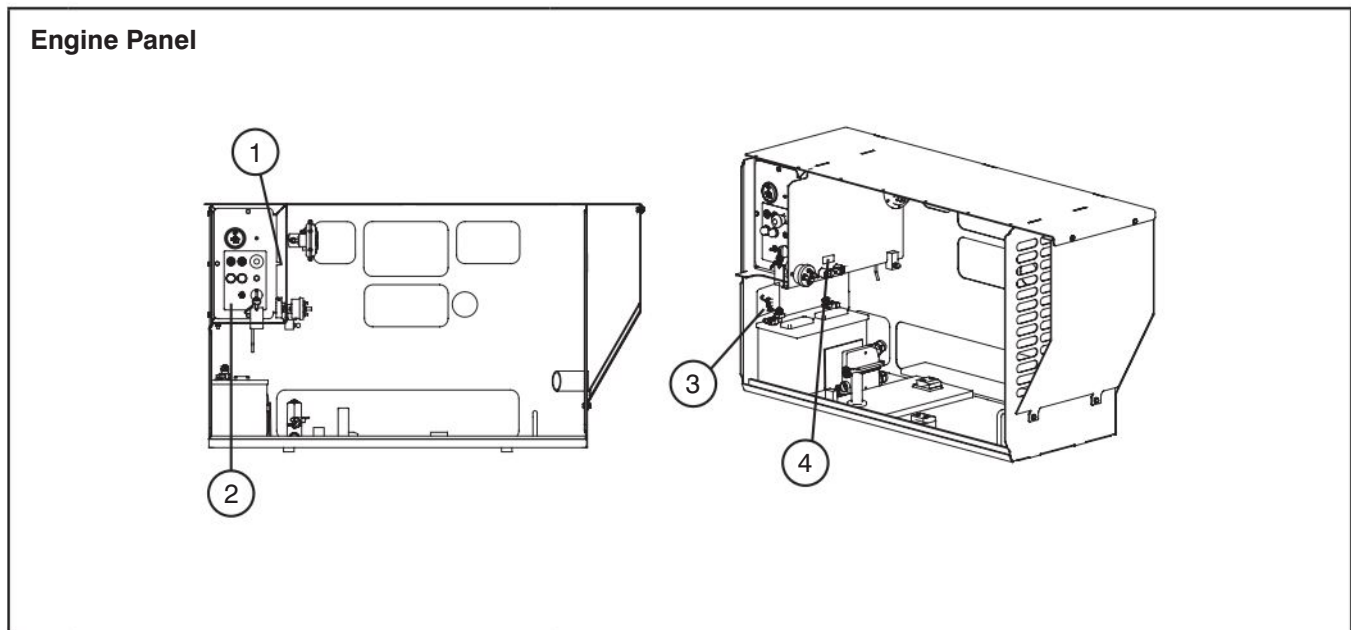

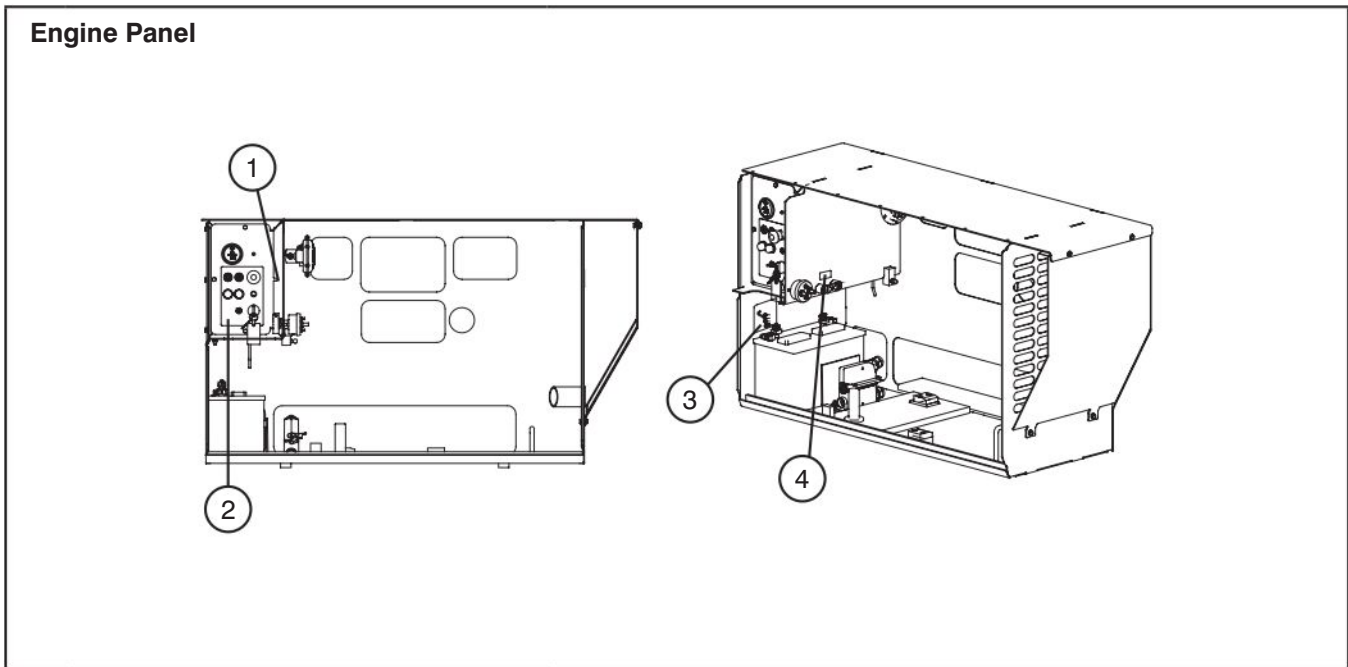

No.	Label Pictorial	Description
1		<p><b>Emergency Main Power Disconnect</b></p> <p>Emergency main power disconnect lever</p>
2		<p><b>Electrical Panel SJ68xxRT</b></p> <p>Push “” to reset ground circuit breaker.</p> <p>Push “” to reset controls circuit breaker.</p> <p>Push “” to stop engine and disable controls (Emergency Stop).</p> <p>Light indicates controls enabled.</p> <p>Push and hold “” to start engine.</p> <p>Push and hold “” to operate choke (dual fuel) or “” glow plugs (diesel).</p> <p>Select “” gasoline or “” propane. Light “” indicates glow plug operation (diesel).</p> <p>Select “” to raise or “” to lower platform.</p> <p>Select “” to enable platform controls, “” to allow engine run with no controls active or “” to enable base control console.</p> <p>Read operating manual. </p>



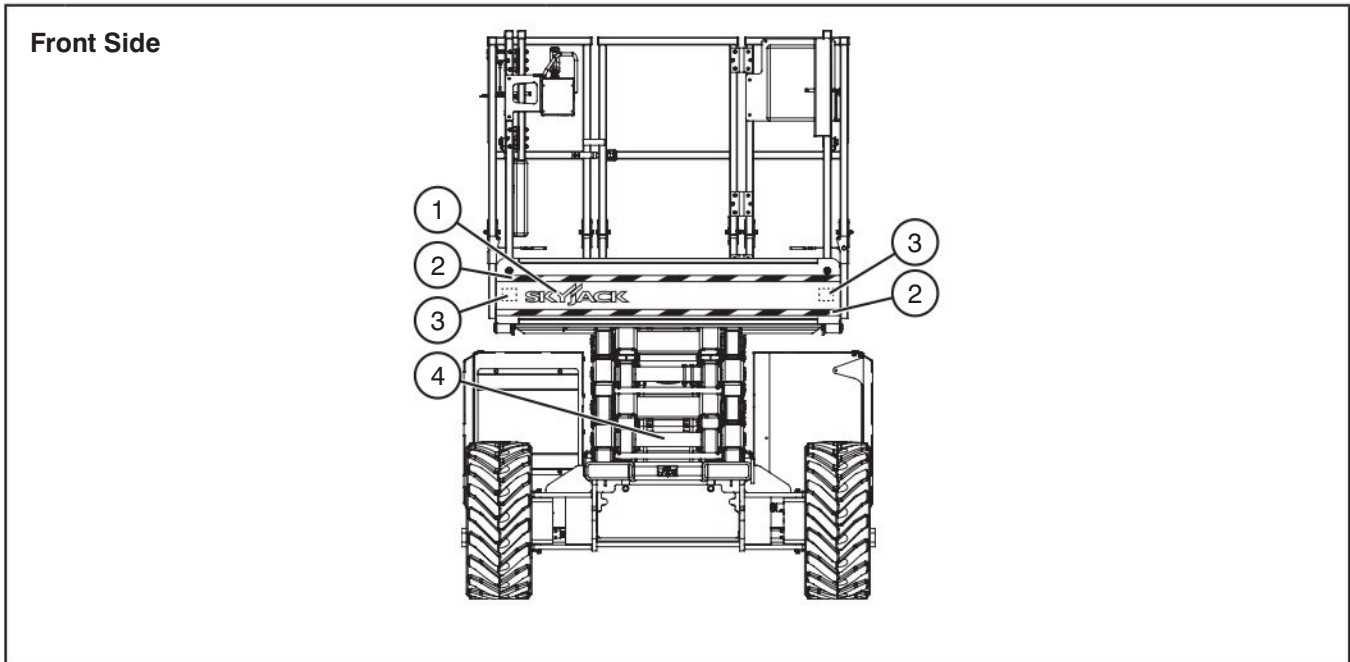

No.	Label Pictorial	Description
3		<p><b>Battery Fuse Assembly</b></p> <p>Assemble fuse as shown. Torque to value indicated.</p>
4		<p><b>Fuse</b></p> <p>Fuse location</p>

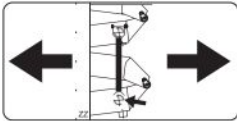

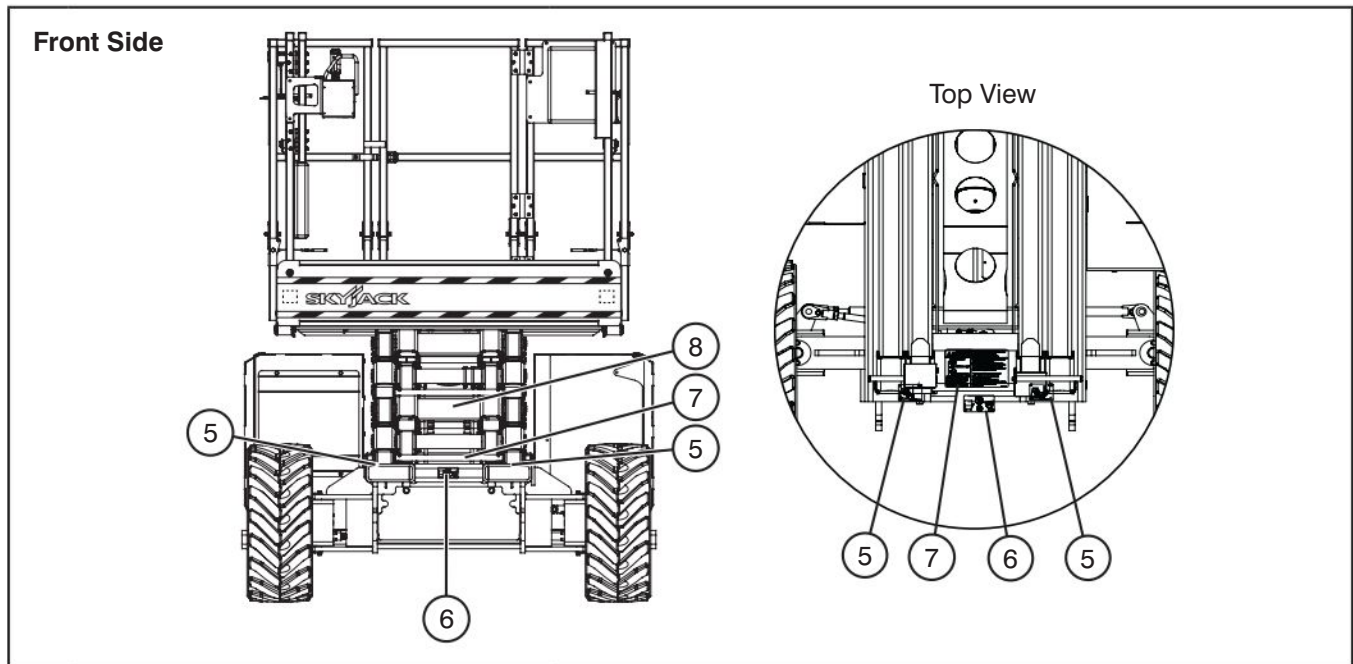
No.	Label Pictorial	Description
1		<p><b>Skyjack Logo</b> Small Skyjack logo - blue</p>
2		<p><b>Caution Tape Stripe</b> Caution stripe</p>
3		<p><b>Harness Anchorage</b> Anchor safety belt/harness tethers here.</p>
4		<p><b>Maintenance Support</b> Deploy maintenance support here.</p>

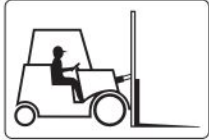

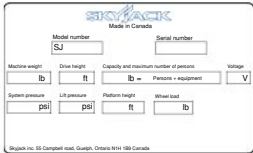
No.	Label Pictorial	Description
5		<p><b>Forklift Pocket</b></p> <p>Insert fork fully into pocket to lift aerial platform.</p>
6		<p><b>Lift and Tie Down Points</b></p> <p>Only use these points for lifting or tying down.</p>
7		<p><b>Maintenance Support</b></p> <p>Instructions on use of maintenance support</p>
8		<p><b>Serial Plate</b></p> <p>Product identification and specifications</p>



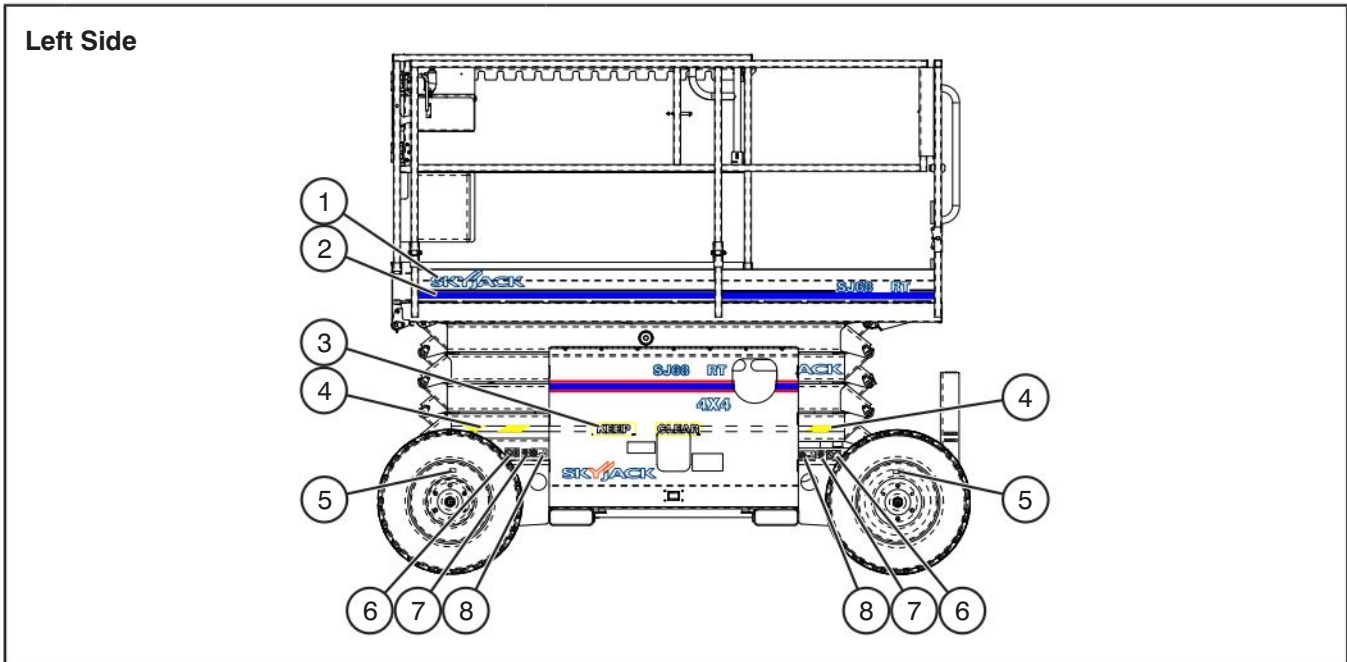





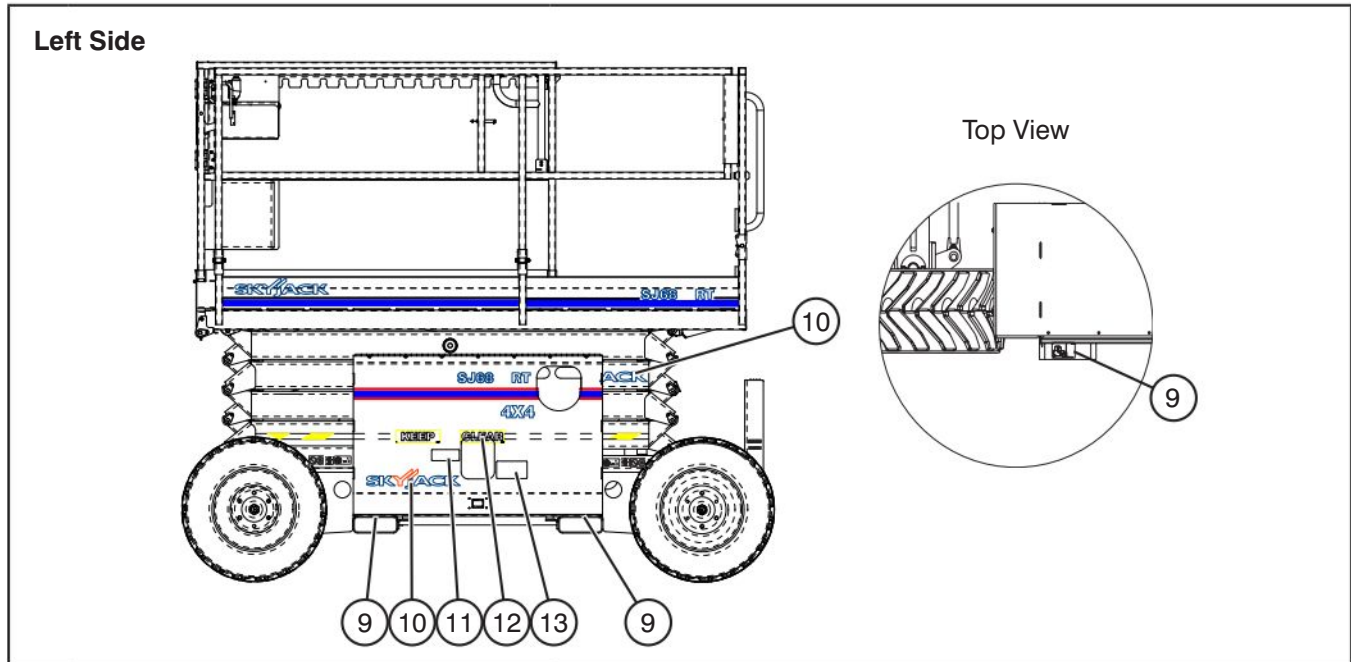





No.	Label Pictorial	Description
1		<b>Skyjack Logo</b> Small Skyjack logo - blue
2		<b>Tape Blue/White</b> Skyjack pinstripe
3		<b>"Keep"</b> Keep clear.
4		<b>Caution Tape Stripe</b> Caution stripe
5		<b>Tire Sealant</b> Indicates that tire sealant is present inside the tires.
6		<b>Foam-filled Tire</b> Indicates foam-filled tire only.
7		<b>Wheel Load 1635 kg/3600 lb.</b> Indicates rated wheel load.
8		<b>Wheel Specifications</b> Refer to manual for wheel type, offset, pressure and torque.

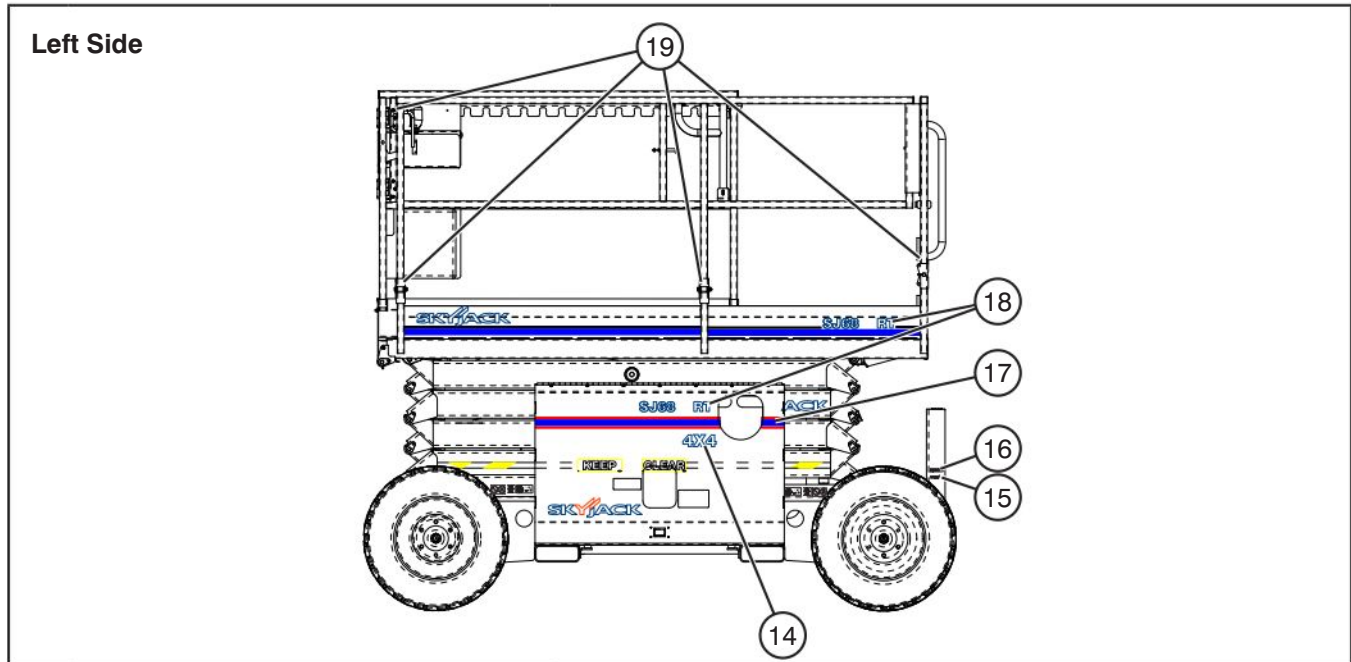



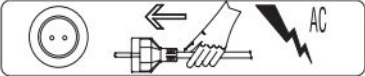



No.	Label Pictorial	Description
9		<p><b>Forklift Pocket</b></p> <p>Insert fork fully into pocket to lift aerial platform.</p>
10		<p><b>Skyjack Logo</b></p> <p>Small Skyjack logo - blue and red</p>
11		<p><b>Towing/Pushing/Winching Procedure</b></p> <p>Instructions for towing, pushing or winching.</p>
12		<p><b>“Clear”</b></p> <p>Keep clear.</p>
13		<p><b>Emergency Lowering Procedure</b></p> <p>In case of emergency, follow procedure outlined in label to lower the platform.</p>

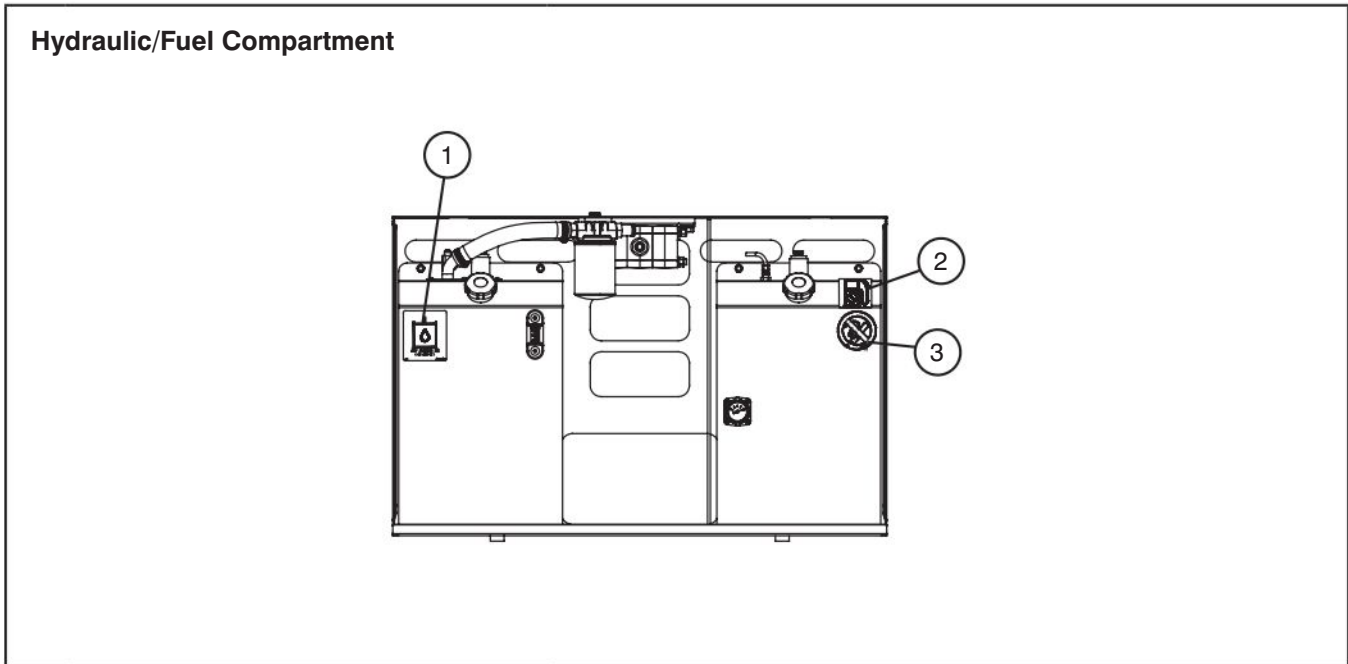



No.	Label Pictorial	Description
14		<p><b>4x4</b></p> <p>Product identifier - 4 wheel drive</p>
15		<p><b>Connect AC Supply</b></p> <p>Connect AC supply here.</p>
16		<p><b>Connect Air Supply</b></p> <p>Connect platform air supply here.</p>
17		<p><b>Tape - Red/Blue/Red</b></p> <p>Skyjack pinstripe</p>
18	<p><b>SJ6826RT</b></p> <p><b>SJ6832RT</b></p>	<p><b>Model Number*</b></p> <p>Product Identifier</p> <p>*Model number will vary, may not be as shown.</p>
19		<p><b>Railing Pins (Vertical)</b></p> <p>WARNING! Falling Hazard. Ensure hinged railing is pinned.</p>

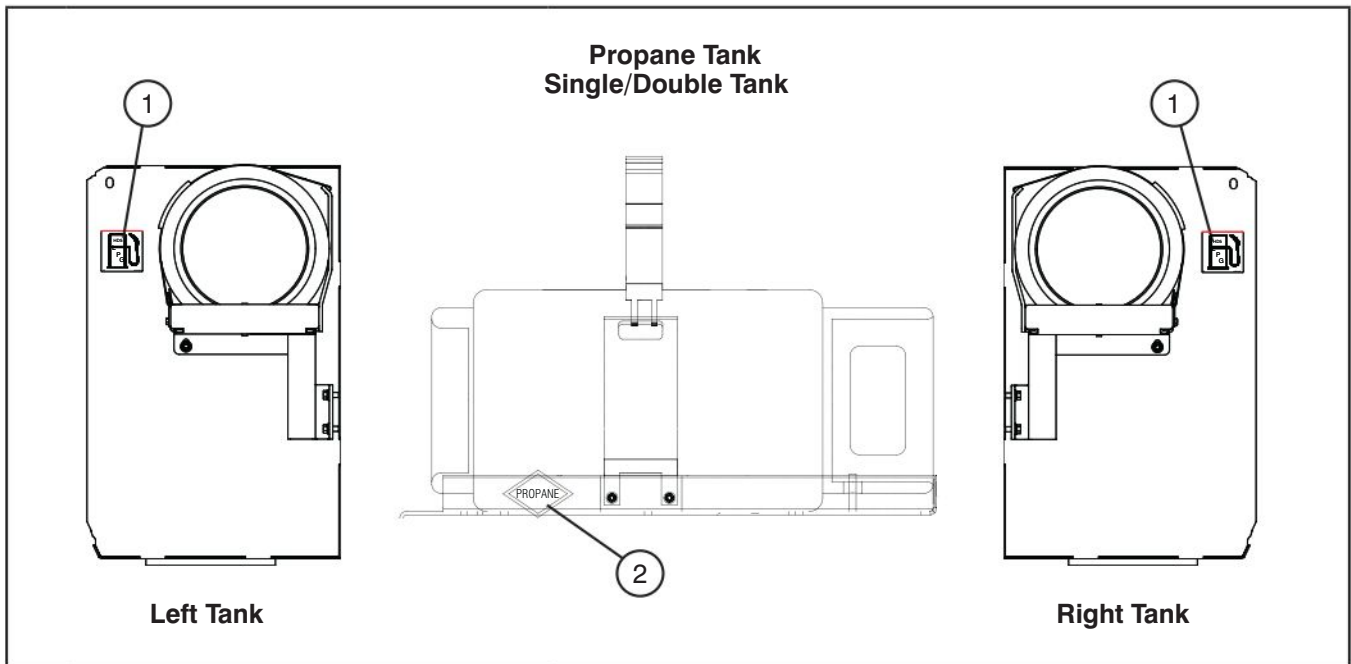

No.	Label Pictorial	Description
1		<p><b>Hydraulic Oil ATF Dexron III</b></p> <p>Replace hydraulic fluid with ATF Dexron III only.</p>
2		<p><b>Diesel</b></p> <p>Use diesel fuel only.</p>
		<p><b>Unleaded Fuel</b></p> <p>Use unleaded gasoline only.</p>
3		<p><b>No Smoking</b></p> <p>Do not smoke near this location.</p>

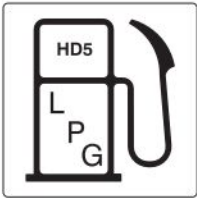



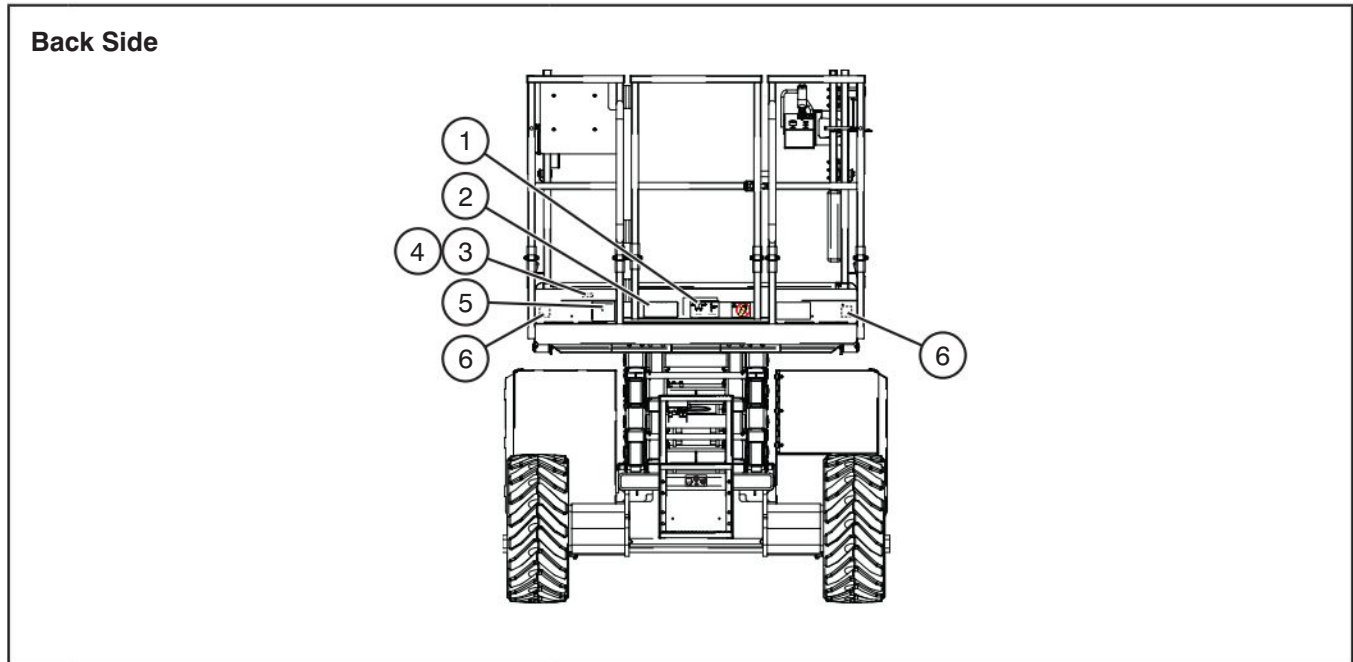

No.	Label Pictorial	Description
1		<p><b>Liquid Propane</b> Use liquid propane only.</p>
2		<p><b>Propane</b> Indicates propane storage location.</p>

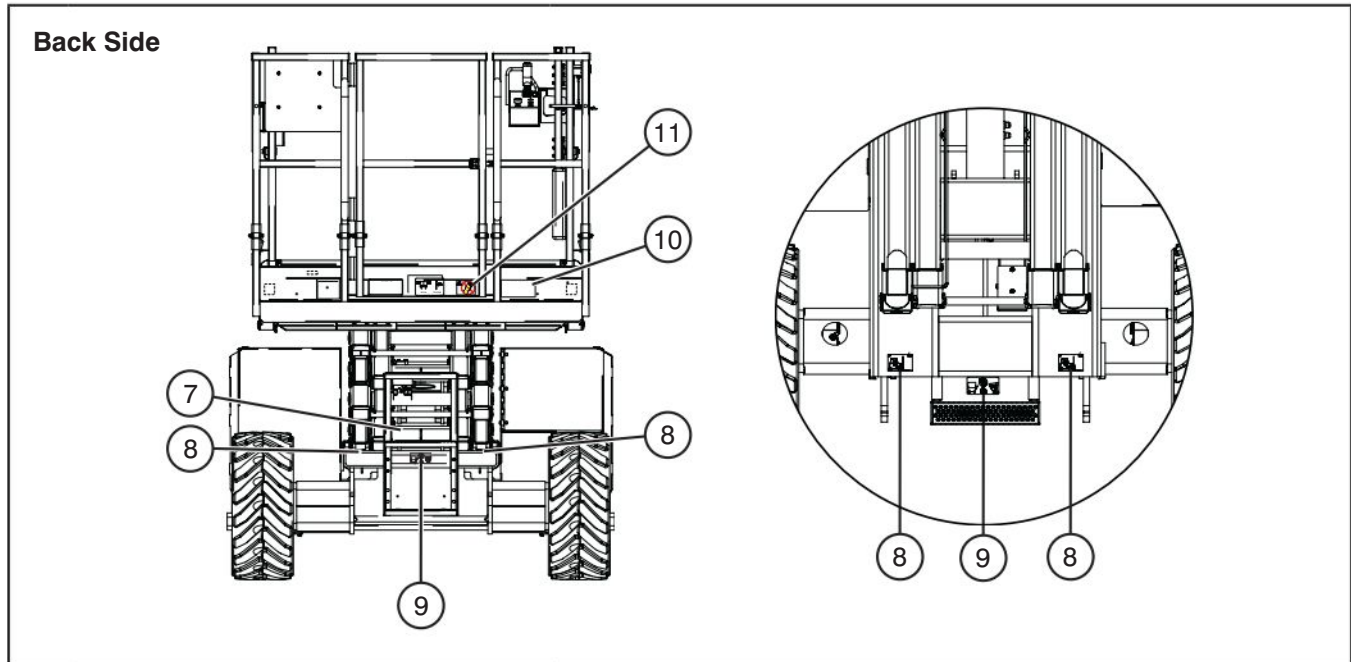

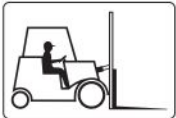
No.	Label Pictorial	Description
1	<p>400 N (90 lb)      12.5 m/s (45 km/h) (28 mph)</p>	<p><b>Horizontal Load Rating</b></p> <p>Apply no more than the indicated side load. Operate below indicated wind speed only.</p>
2	<p><b>SKYJACK</b> This elevating work platform has been designed and tested to the following requirements: - ANSI SIA A92.2-1999 - CSA B364.2-01 - AS 1418.10-1996 It is the responsibility of dealer, owners, users, operators, lessors and lessees to conform to the applicable safety regulations for the operation of this elevating work platform.</p>	<p><b>Standards Compliance</b></p> <p>Indicates standards to which the work platform complies.</p>
3		<p><b>Connect AC Supply</b></p> <p>Connect AC supply here.</p>
4	<p>100 PSI 6.9 BAR</p>	<p><b>Connect Air Supply</b></p> <p>Connect platform air supply here.</p>
5	<p><b>Operator's Check List</b></p> <ul style="list-style-type: none"> <li>1. Inspect and/or read the following daily or at the beginning of each shift:</li> <li>2. Check safety and emergency controls</li> <li>3. Insure protective devices</li> <li>4. Check for obstructions</li> <li>5. Check for electrical and other malfunctions</li> <li>6. Check for missing parts</li> <li>7. Check for missing labels</li> <li>8. Check for electrical, control, warning and signaling malfunctions</li> <li>9. Insure correct use of attachments</li> <li>10. Insure correct use of accessories</li> <li>11. Insure correct use of equipment</li> <li>12. Insure correct use of accessories</li> <li>13. Insure correct use of accessories</li> <li>14. Insure correct use of accessories</li> </ul>	<p><b>Operator's checklist</b></p> <p>Operator's checklist. Perform check prior to use.</p>
6		<p><b>Harness Anchorage</b></p> <p>Anchor safety belt/harness tethers here.</p>

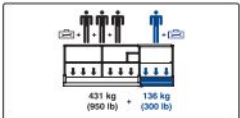
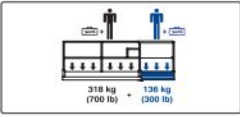

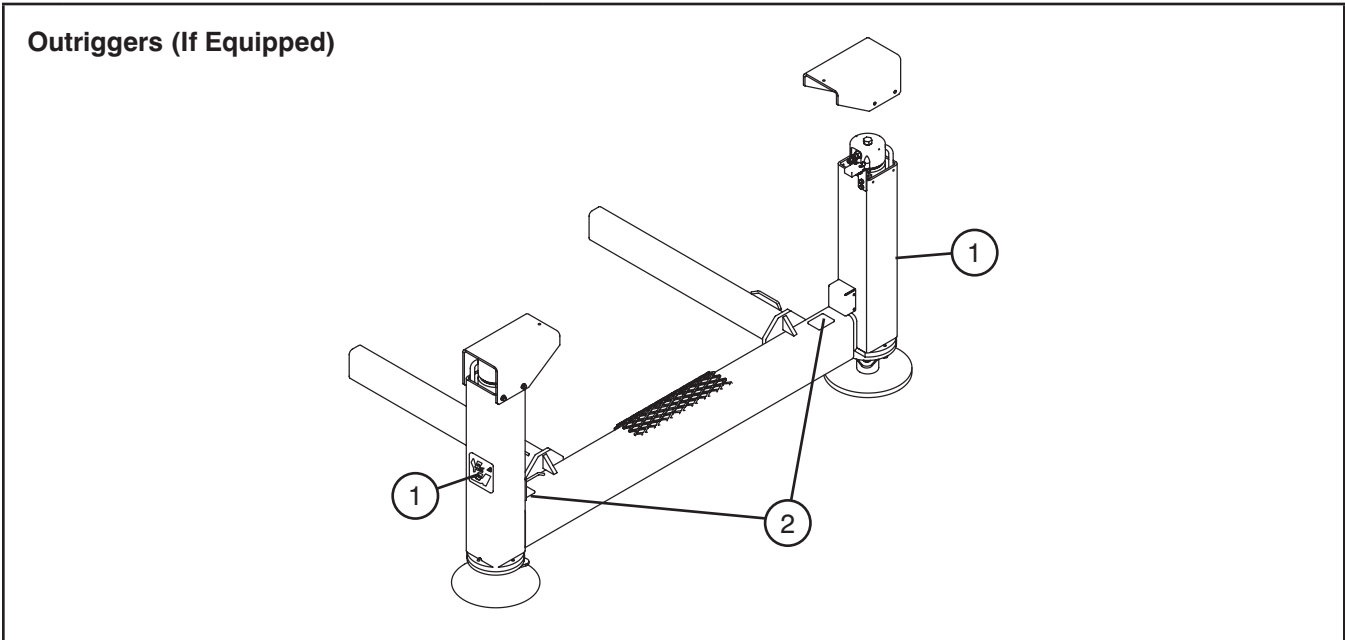

No.	Label Pictorial	Description
7		<p><b>Warning - Do Not Alter</b></p> <p>Aerial platform altering warning</p>
8		<p><b>Forklift Pocket</b></p> <p>Insert fork fully into pocket to lift aerial platform.</p>
9		<p><b>Lift and Tie Down Points</b></p> <p>Only use these points for lifting or tying down.</p>
10		<p><b>Platform Capacity</b></p> <p>Platform capacity label for 6826RT and 6832RT respectively</p> <p>Rated work load in each configuration is as shown. Rated work load includes the weight of both personnel and material. Maximum number of people in each configuration is as shown. Do not exceed total weight or maximum number of people. Load platform uniformly.</p>
		
11		<p><b>No Jewelry</b></p> <p>Caution - Do not wear jewelry.</p>



No.	Label Pictorial	Description
1		<p><b>Crushing Hazard</b>                      Danger - Crushing hazard</p>
2		<p><b>Warning - Do Not Alter</b>                      Aerial platform altering warning</p>

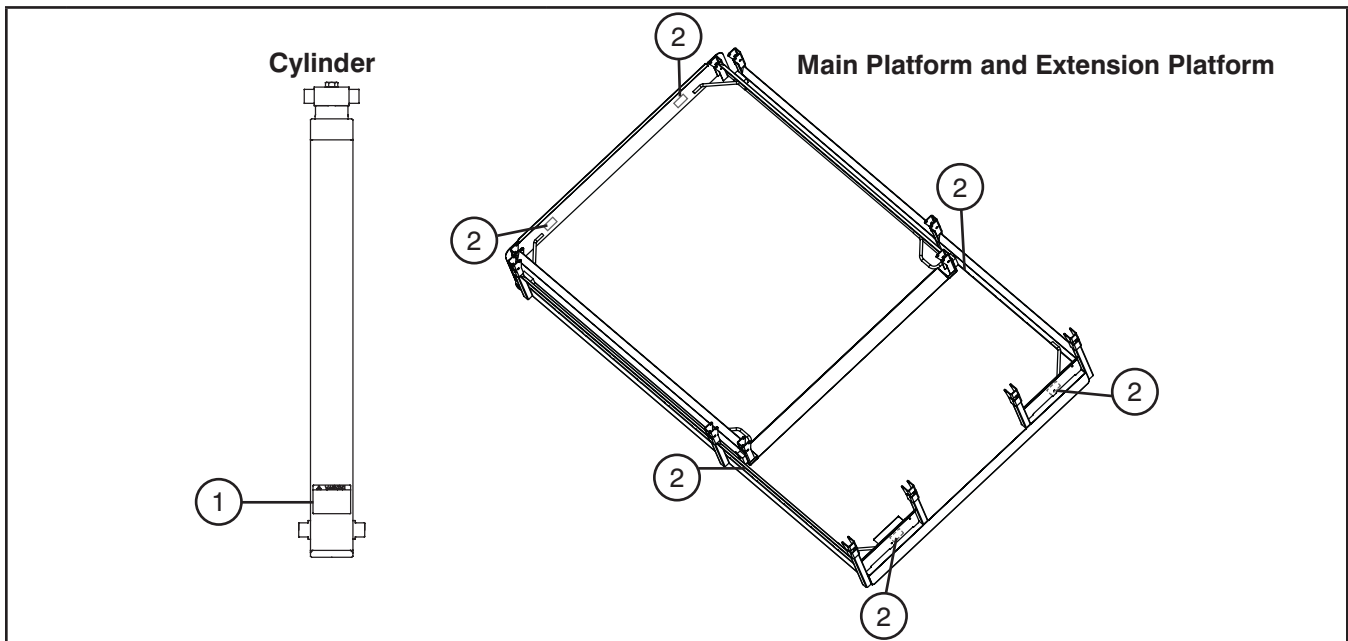

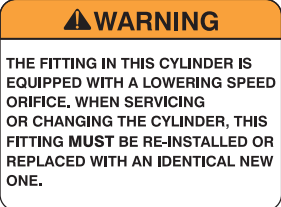

No.	Label Pictorial	Description
1	 <p><b>WARNING</b></p> <p>THE FITTING IN THIS CYLINDER IS EQUIPPED WITH A LOWERING SPEED ORIFICE. WHEN SERVICING OR CHANGING THE CYLINDER, THIS FITTING <b>MUST</b> BE RE-INSTALLED OR REPLACED WITH AN IDENTICAL NEW ONE.</p>	<p><b>Orifice Installed</b></p> <p>Orifice installation warning</p>
2		<p><b>Harness Anchorage</b></p> <p>Anchor safety belt/harness tethers here.</p>

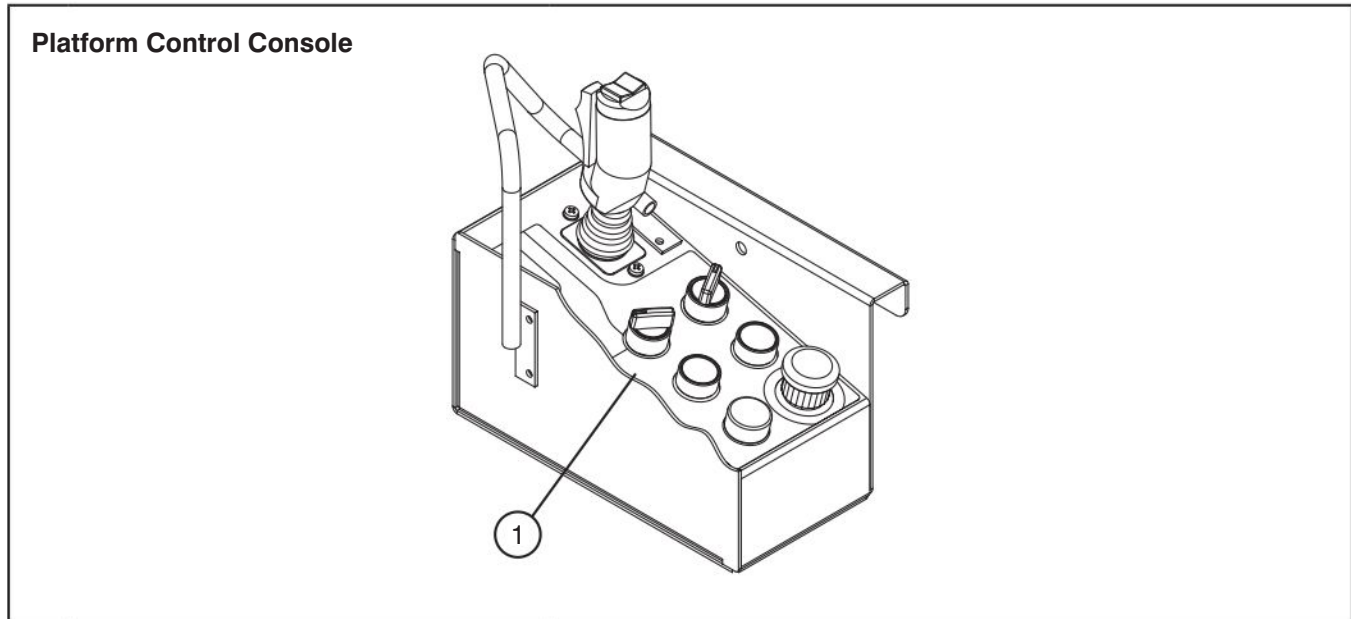

No.	Label Pictorial	Description
1		<p><b>Platform Control Console 68xxRT</b></p> <p>Squeeze “” trigger to enable controller.</p> <p>Operate “” rocker switch to steer.</p> <p>Move controller forward “” to raise or backward “” to lower platform.</p> <p>Move controller forward “” to drive forward or backward “” to drive reverse.</p> <p>Select either “” lift mode, “” drive mode with low speed (high torque) or “” drive mode with high speed (low torque).</p> <p>Select either “” low or “” high engine throttle speed.</p> <p>Push and hold “” to start engine.</p> <p>Push and hold “” to operate choke (dual fuel) or “” glow plugs (diesel).</p> <p>Push “” to sound horn.</p> <p>Push “” to stop engine and disable controls (Emergency Stop).</p> <p>Light indicates controls enabled.</p> <p>Read operating manual. </p>

Outrigger Control Console (If Equipped)

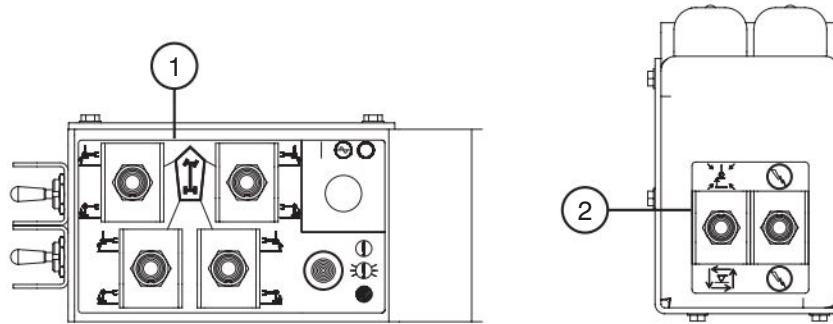

No.	Label Pictorial	Description
1		<p><b>Manual Outrigger Control Console with Generator</b></p> <p>Select “” retract or “” extend for each outrigger.</p> <p>Select “” to enable or “” to disable generator.</p> <p>Indicates leveling system status:</p> <ul style="list-style-type: none"> <li> <b>Off:</b> The outriggers are fully retracted.</li> <li> <b>Flashing Rapidly:</b> The outriggers are extending but the platform is not level.</li> <li> <b>Flashing:</b> The outriggers are extended but the platform is not yet level.</li> <li> <b>Solid:</b> The outriggers are extended and the platform is level.</li> </ul>
2		<p><b>Automatic Outrigger Control Console</b></p> <p>Select “” to retract all outriggers or “” to extend all outriggers with automatic leveling.</p> <p>Select “” to enable manual or automatic outrigger controls.</p>

**California Proposition 65**



**WARNING**

**Engine exhaust and some of its constituents are known to the State of California to cause cancer, birth defects, and other reproductive harm.**

Battery posts, terminals, and related accessories contain lead and lead compounds, chemicals known to the State of California to cause cancer, birth defects, and other reproductive harm.

**WASH HANDS AFTER HANDLING.**



Reliable lift solutions by people who care.

[www.skyjack.com](http://www.skyjack.com)